

HOW TO DRAFT THE SHADOW OF A SIMPLE OBJECT

Rebecca B. Bennett

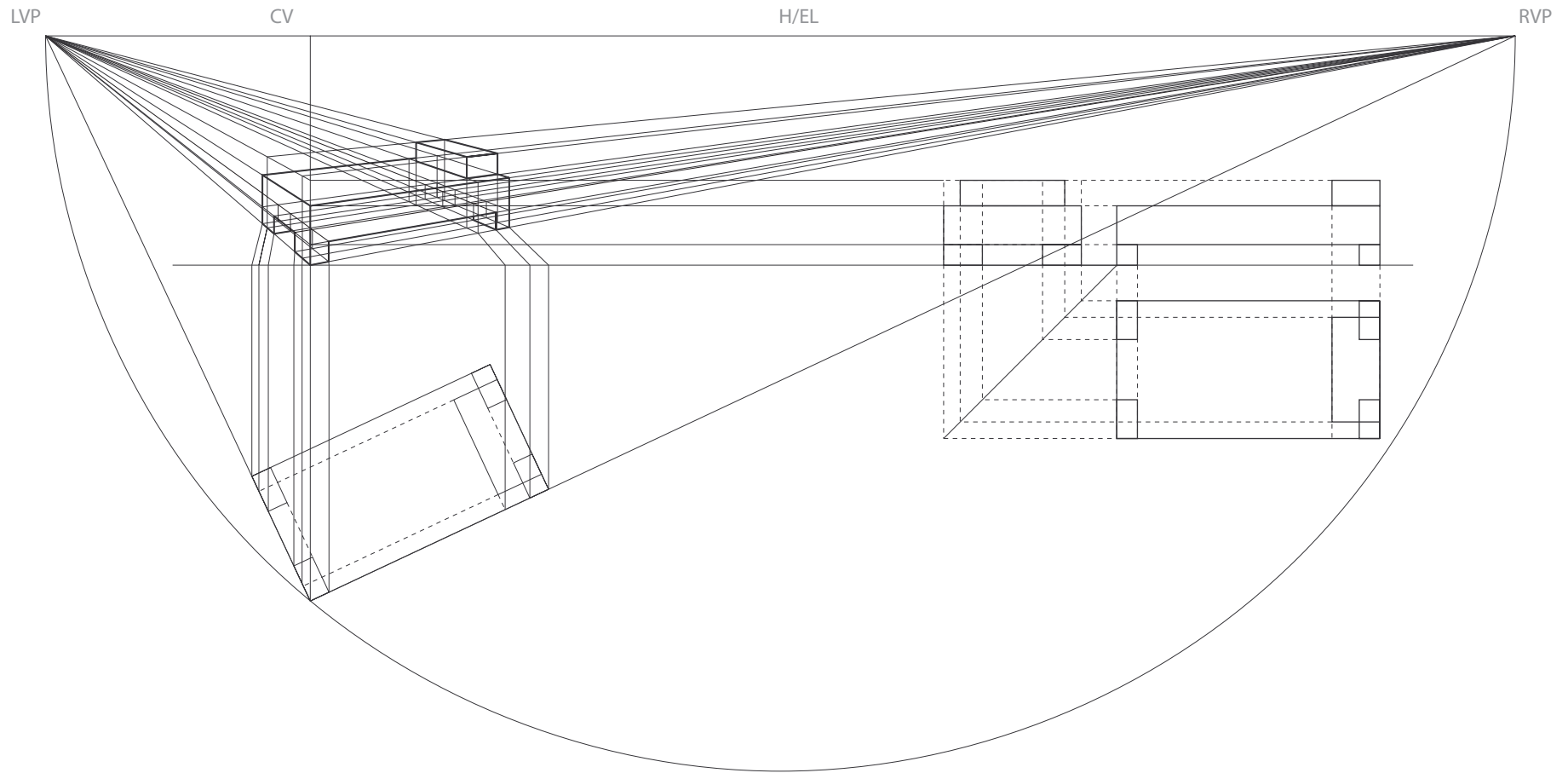

step 1
First, draft your object in two-point perspective

HOW TO DRAFT THE SHADOW OF A SIMPLE OBJECT

Rebecca B. Bennett

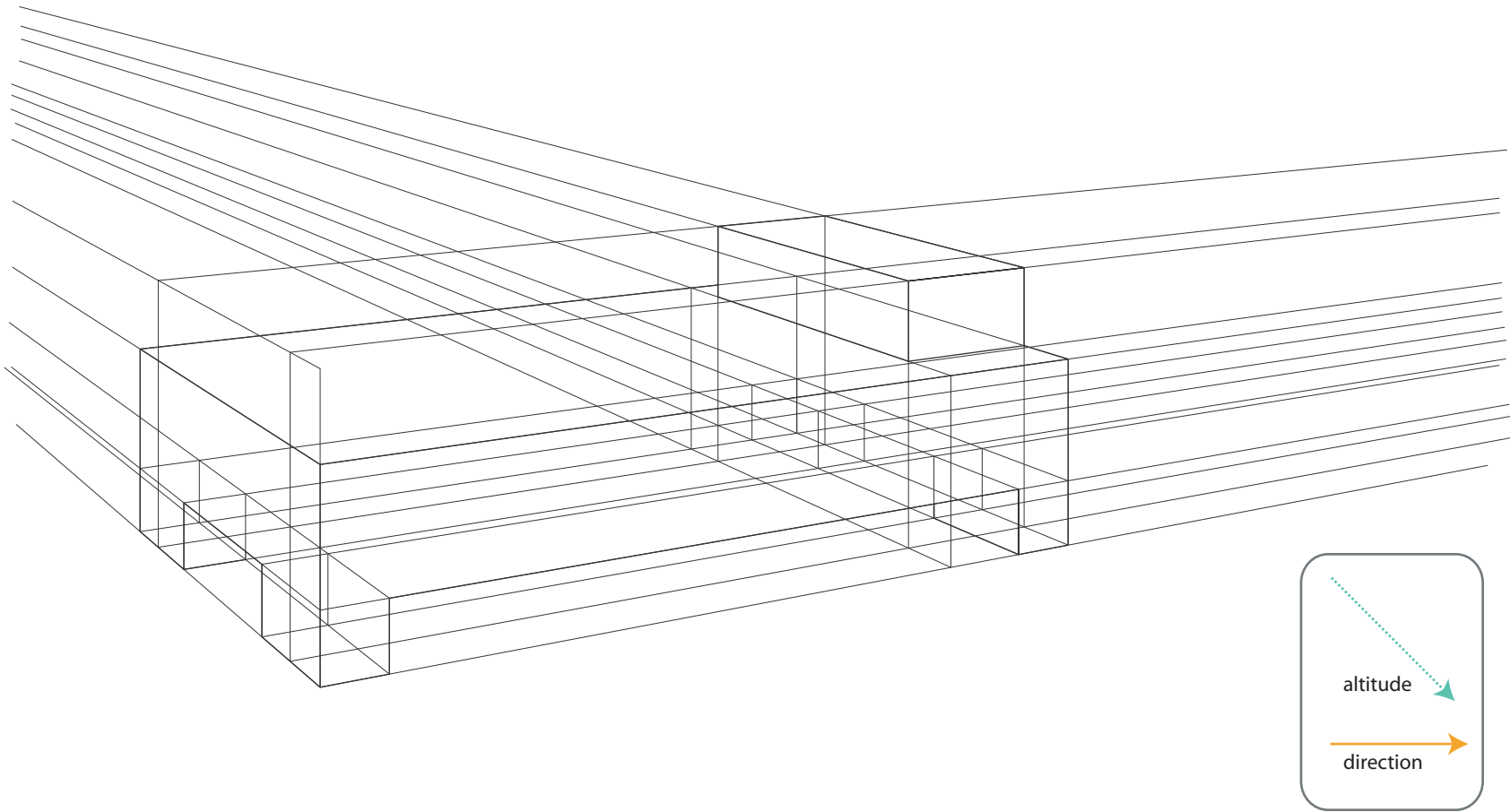

step 2

Then, establish the light direction (which will be parallel to the H/EL if you are using sunlight) and the altitude (this is up to you but I recommend that it be near 45 degrees)

HOW TO DRAFT THE SHADOW OF A SIMPLE OBJECT

Rebecca B. Bennett

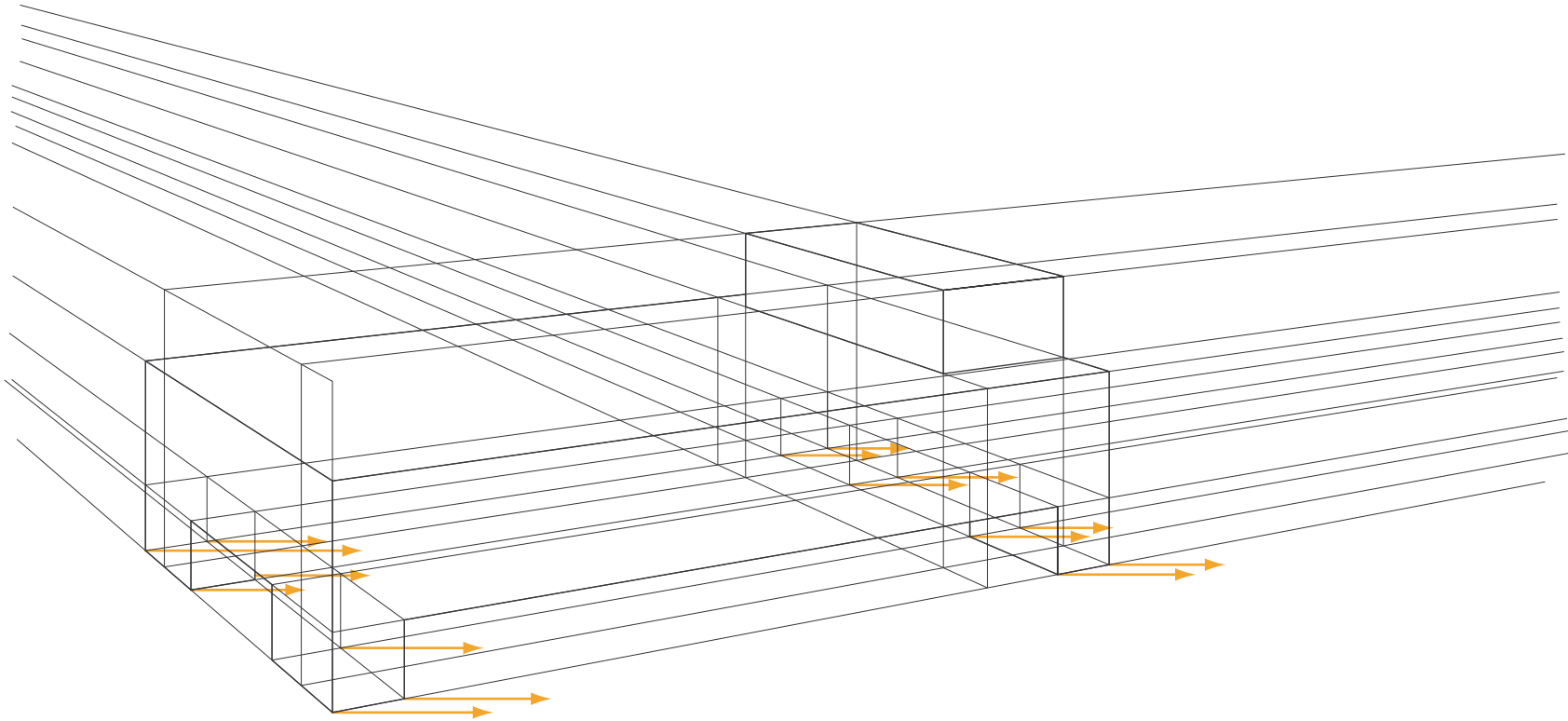

step 3
From every point where the object touches the ground, extend a line for the direction of the light

HOW TO DRAFT THE SHADOW OF A SIMPLE OBJECT

Rebecca B. Bennett

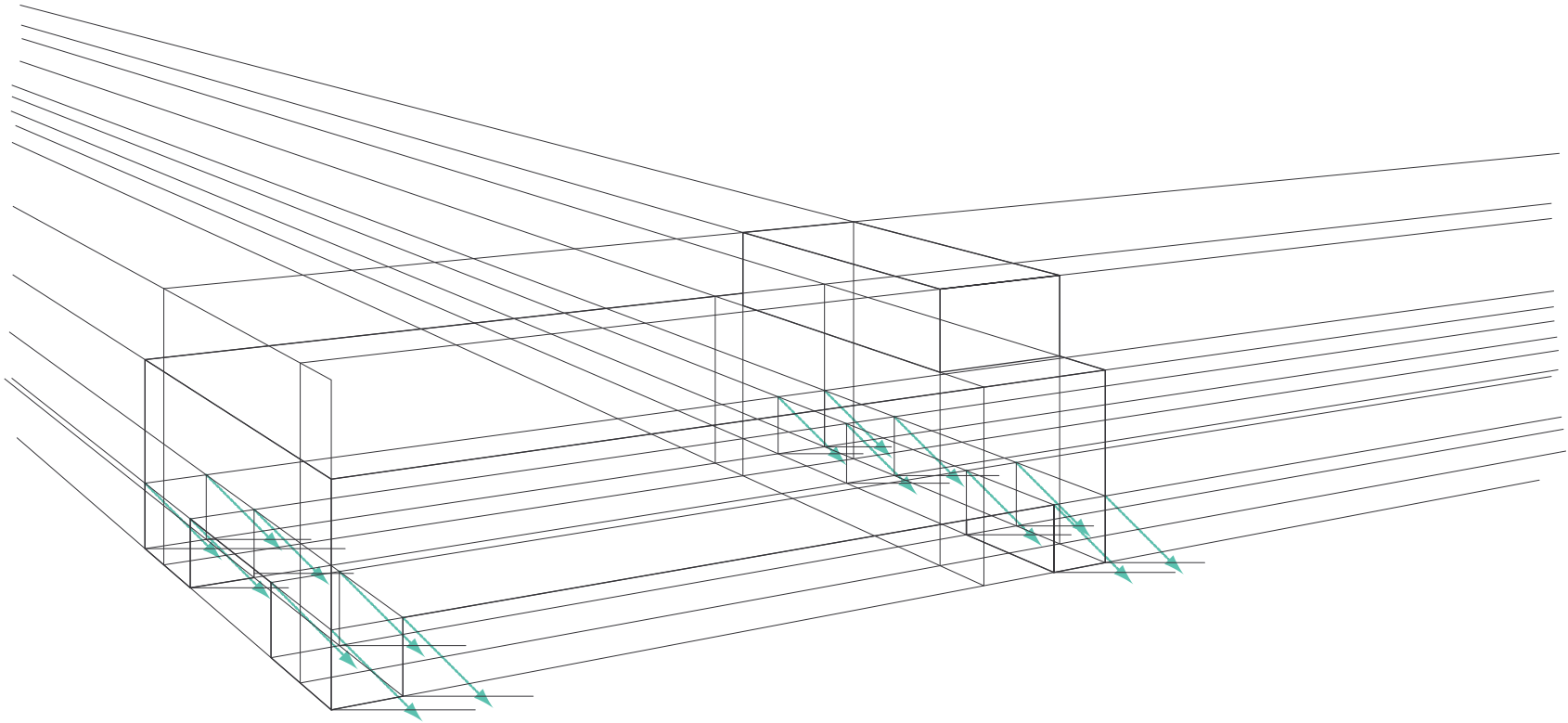

step 4
For every point on the top of the bottom of the bed, draft a line for the altitude

HOW TO DRAFT THE SHADOW OF A SIMPLE OBJECT

Rebecca B. Bennett

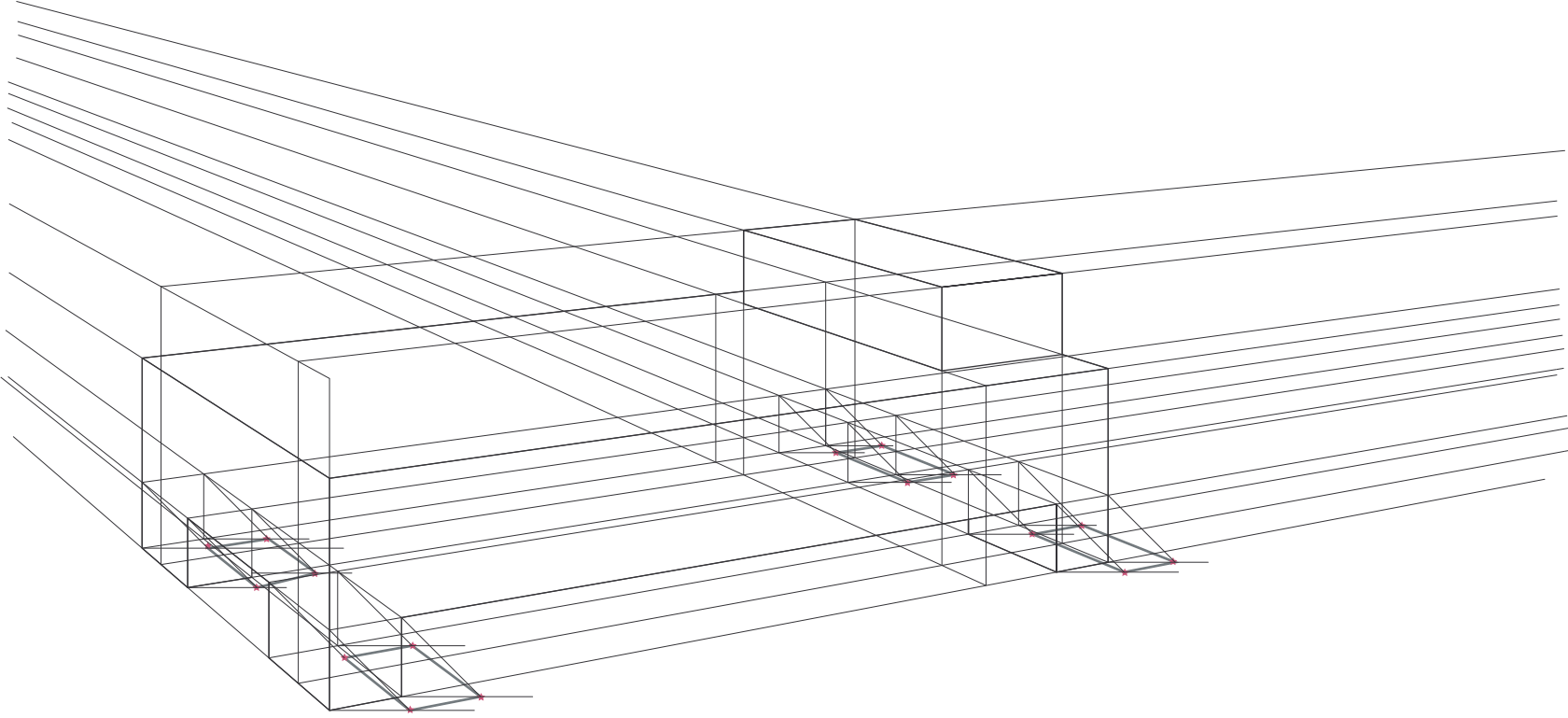

step 5
Connect these together

HOW TO DRAFT THE SHADOW OF A SIMPLE OBJECT

Rebecca B. Bennett

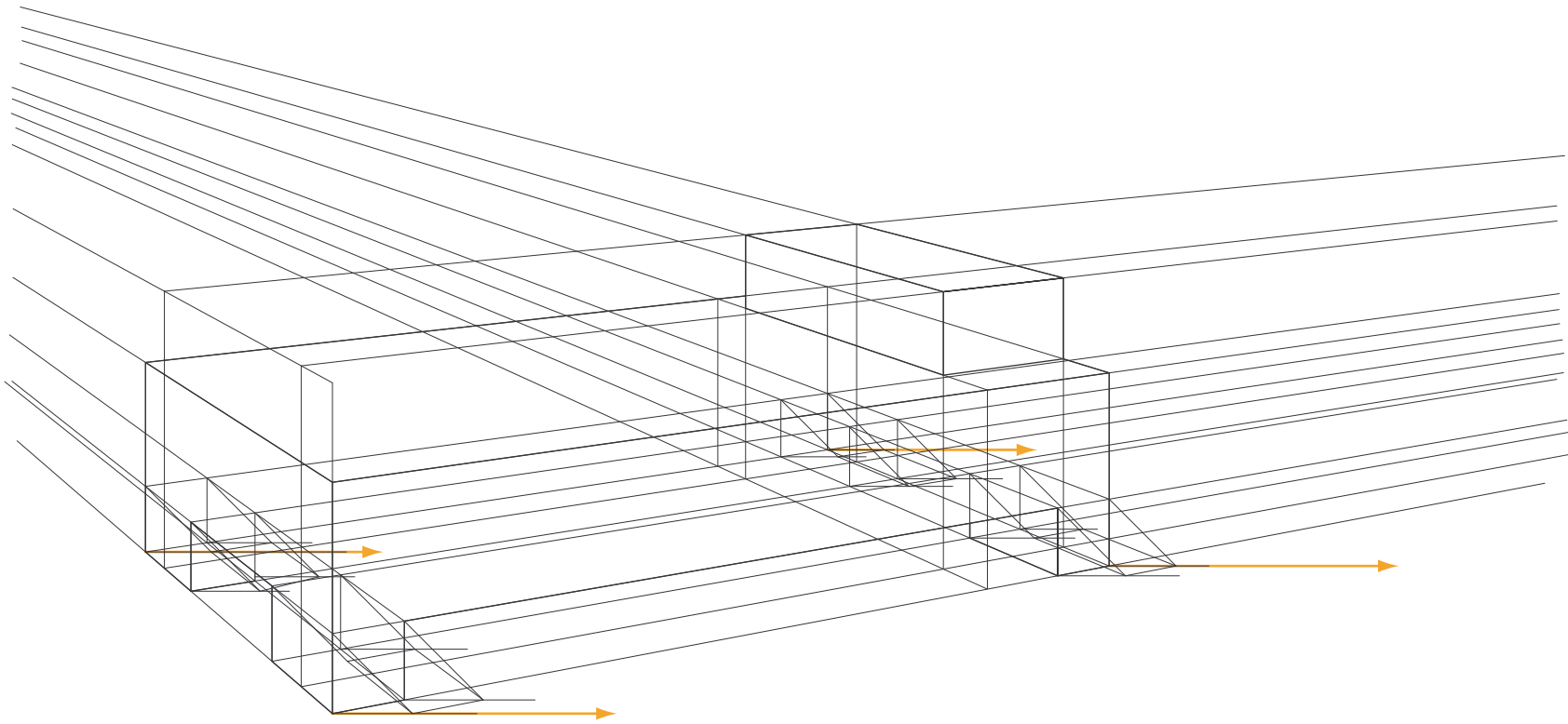

step 6

Extend lines from the top of the mattress down to the ground and extend a line for the direction of the light (this is like casting the shadow of a floating box)

HOW TO DRAFT THE SHADOW OF A SIMPLE OBJECT

Rebecca B. Bennett

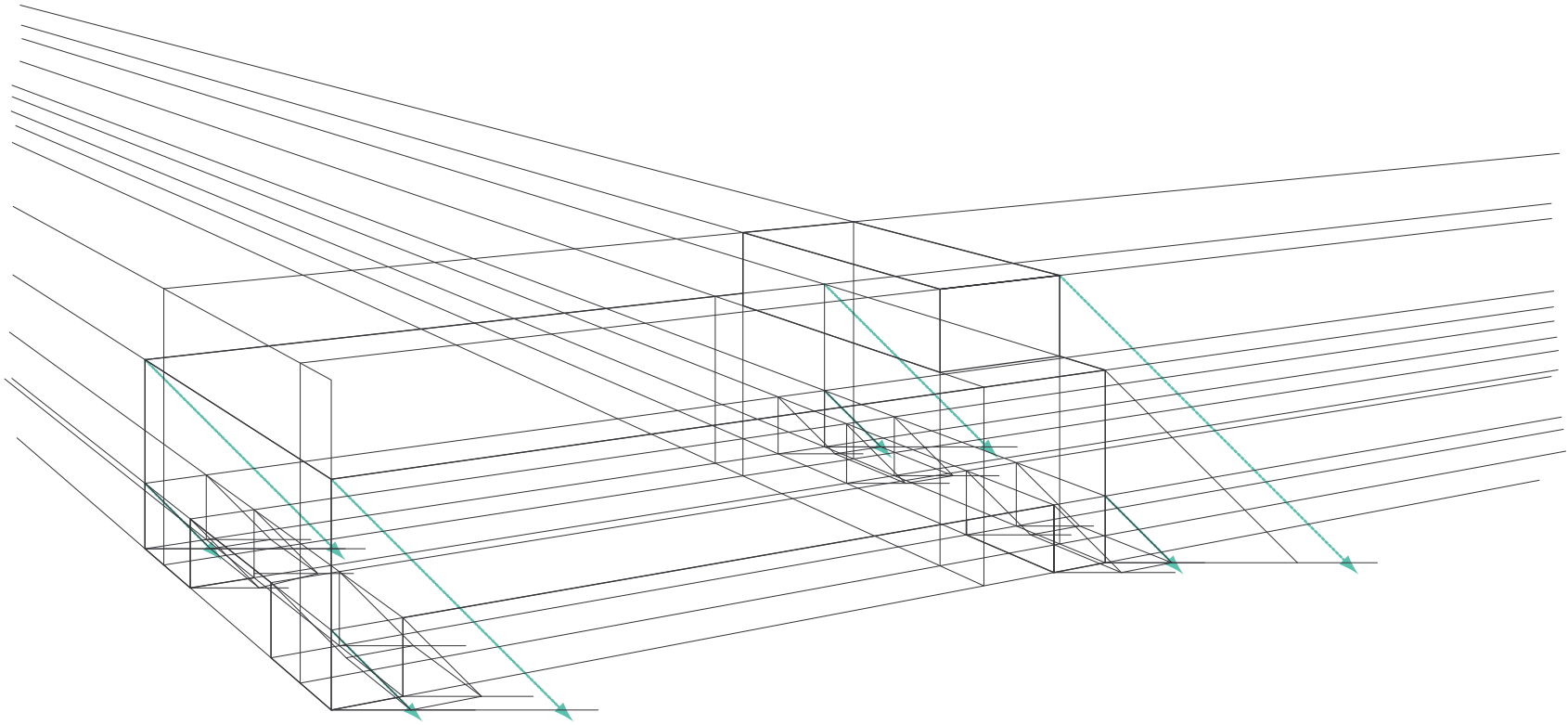

step 7
For every point on the top of the bottom and bottom of the mattress, draft a line for the altitude

HOW TO DRAFT THE SHADOW OF A SIMPLE OBJECT

Rebecca B. Bennett

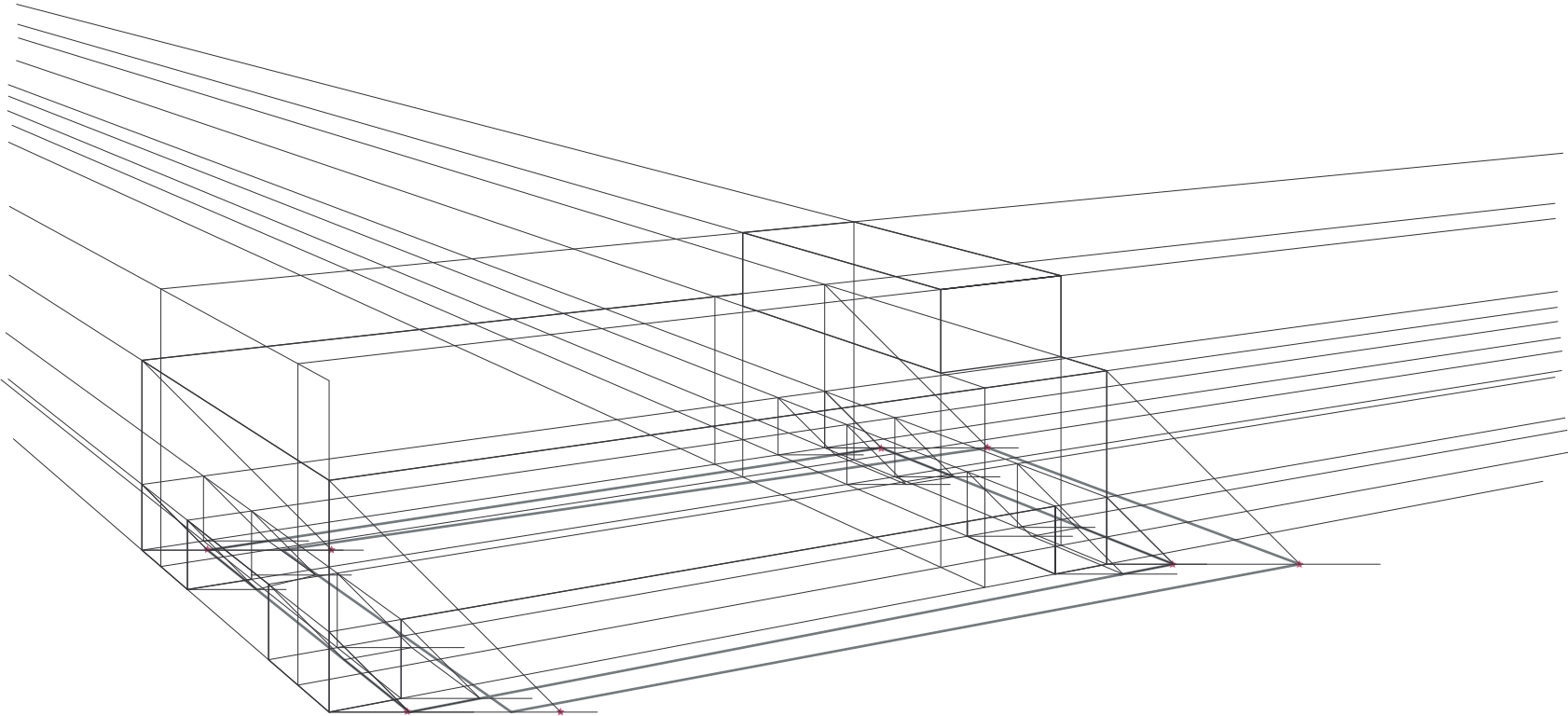

step 8
Connect these together

HOW TO DRAFT THE SHADOW OF A SIMPLE OBJECT

Rebecca B. Bennett

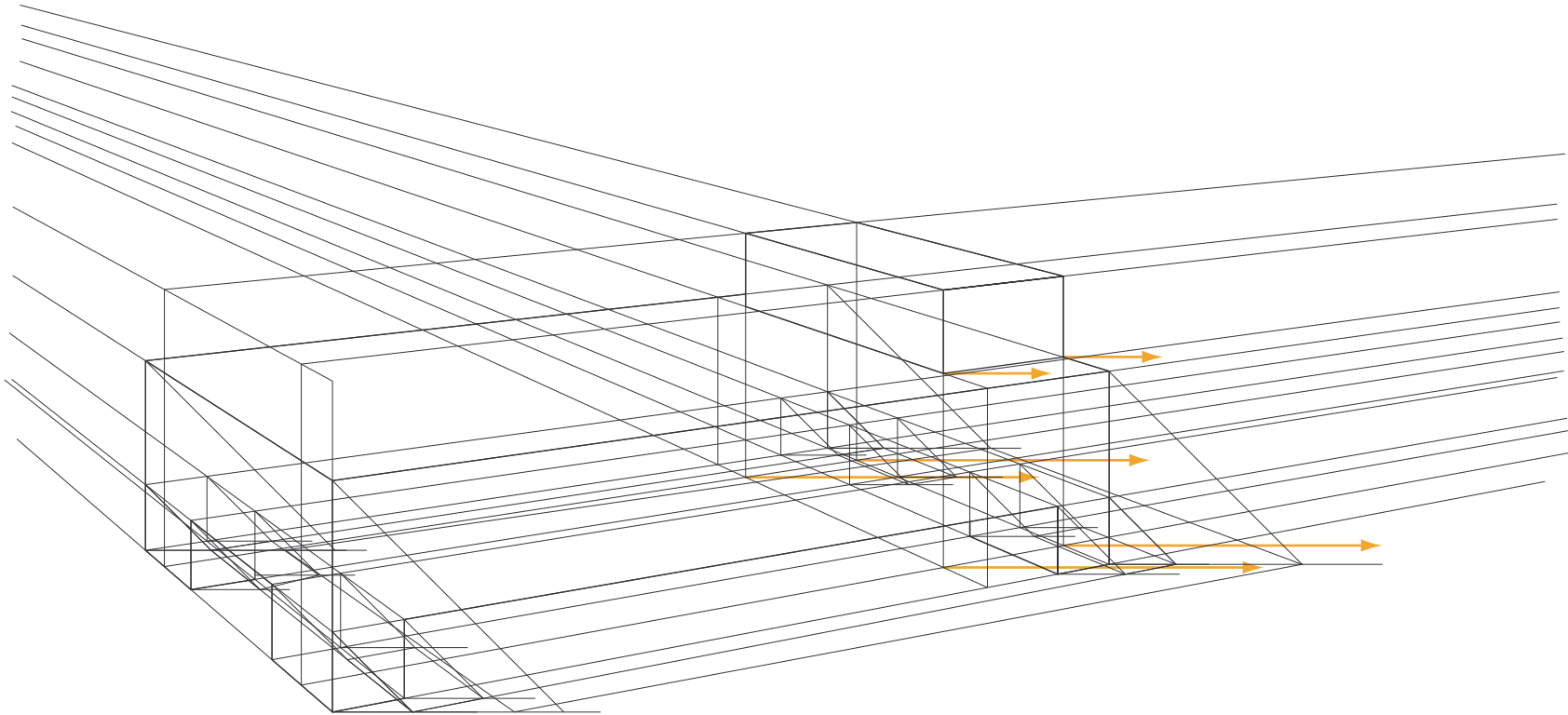

step 9

Extend lines from the top of the bed down to the ground and extend a line for the direction of the light (this is like casting the shadow of a floating box)

HOW TO DRAFT THE SHADOW OF A SIMPLE OBJECT

Rebecca B. Bennett

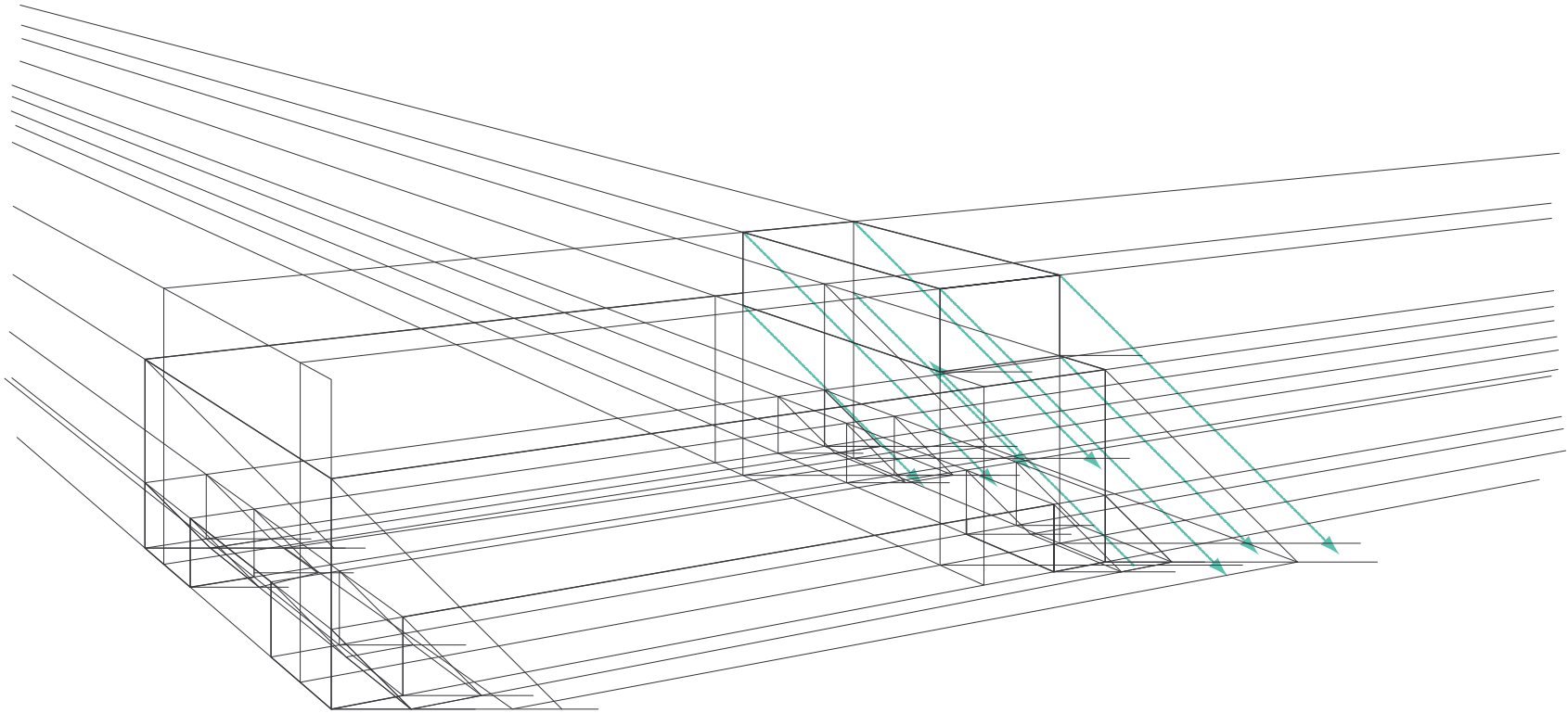

step 10

For every point on the top of the bottom and bottom of the top of the bed, draft a line for the altitude

HOW TO DRAFT THE SHADOW OF A SIMPLE OBJECT

Rebecca B. Bennett

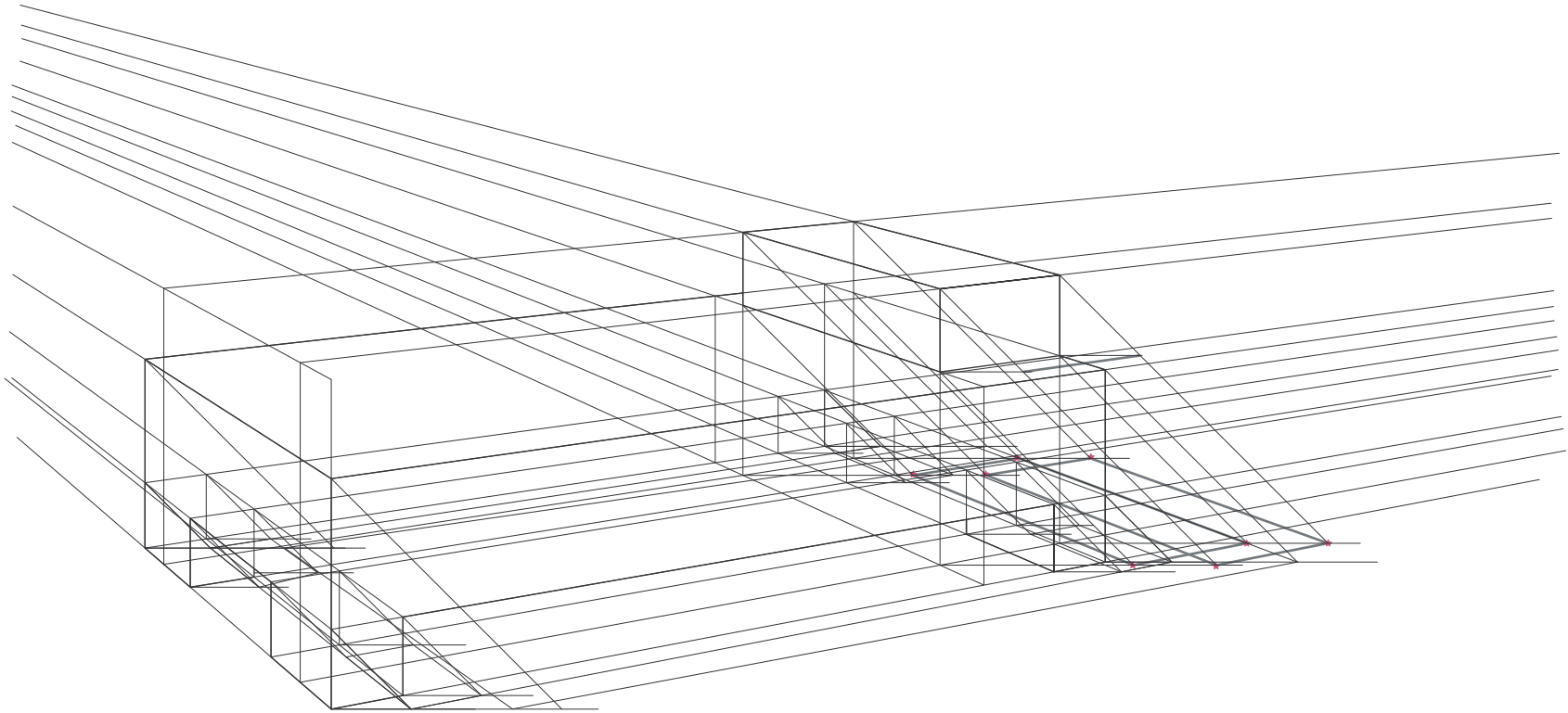

step 11

Connect these together (depending on the light altitude you have chosen, the shadow may be cast on to the ground, the mattress or both)

HOW TO DRAFT THE SHADOW OF A SIMPLE OBJECT

Rebecca B. Bennett

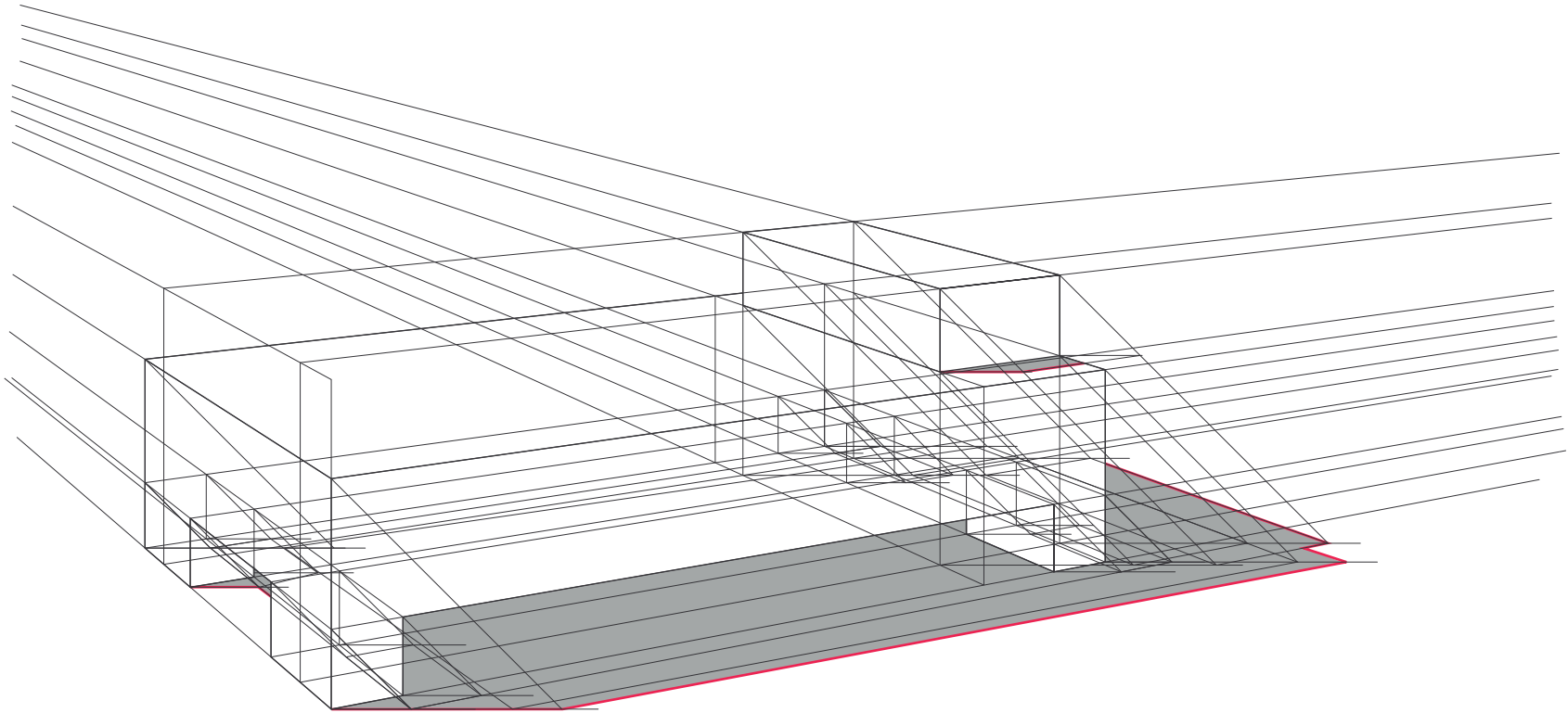

step 12

Find the final outline of the entire shadow. It should look like a squashed version of the original object.