

HOW TO DRAFT A BASIC REFLECTION
Rebecca B. Bennett

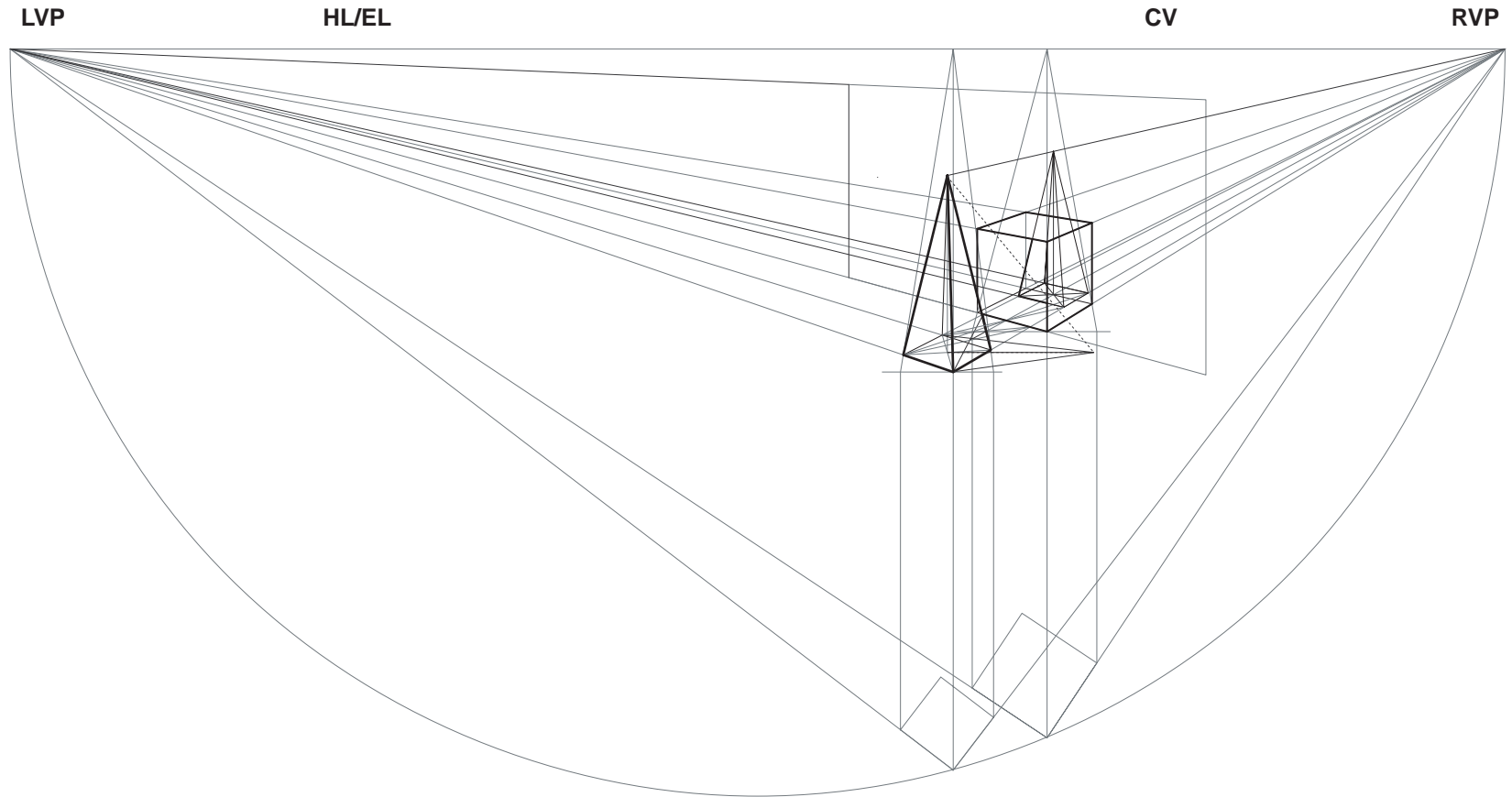

NOTES:

step 1
Draft the cube,
the pyramid, the
pyramid's
shadow, and the
reflection of the
pyramid

HOW TO DRAFT A BASIC REFLECTION
Rebecca B. Bennett

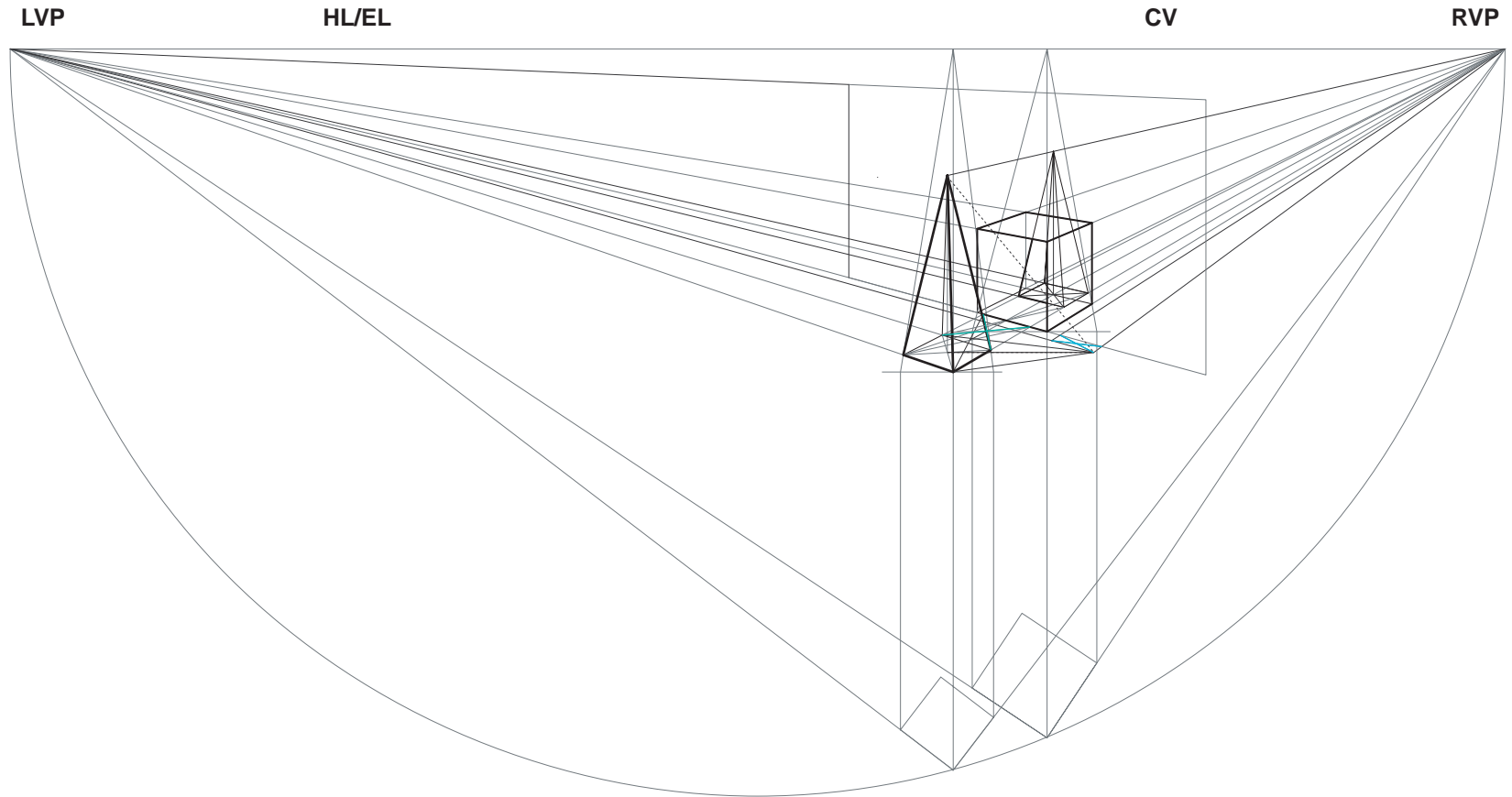

NOTES:

step 5
Make an "X"
between the
corners the new
rectangle in
perspective

HOW TO DRAFT A BASIC REFLECTION
Rebecca B. Bennett

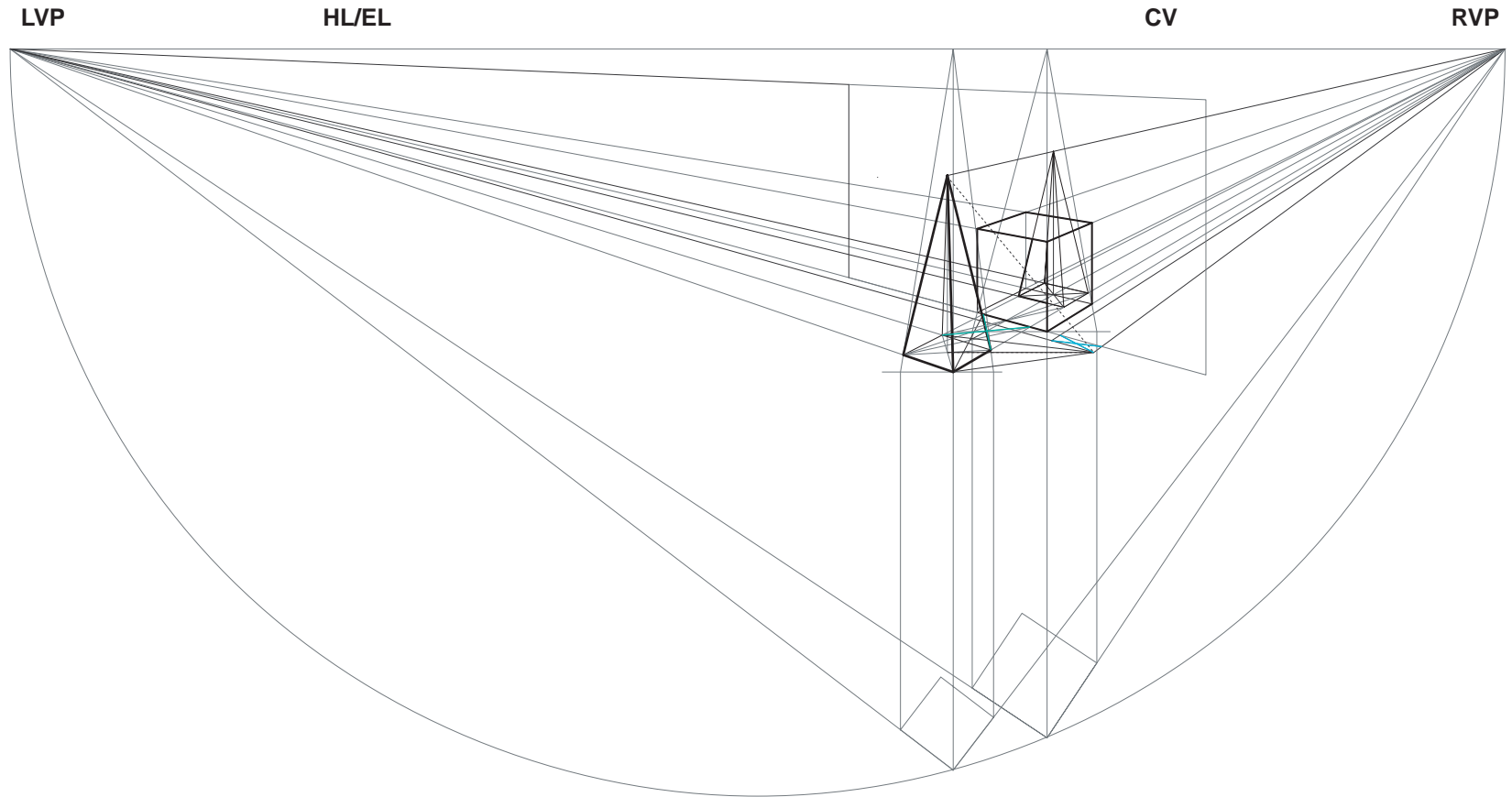

NOTES:

step 5
Make an "X"
between the
corners the new
rectangle in
perspective

HOW TO DRAFT A BASIC REFLECTION

Rebecca B. Bennett

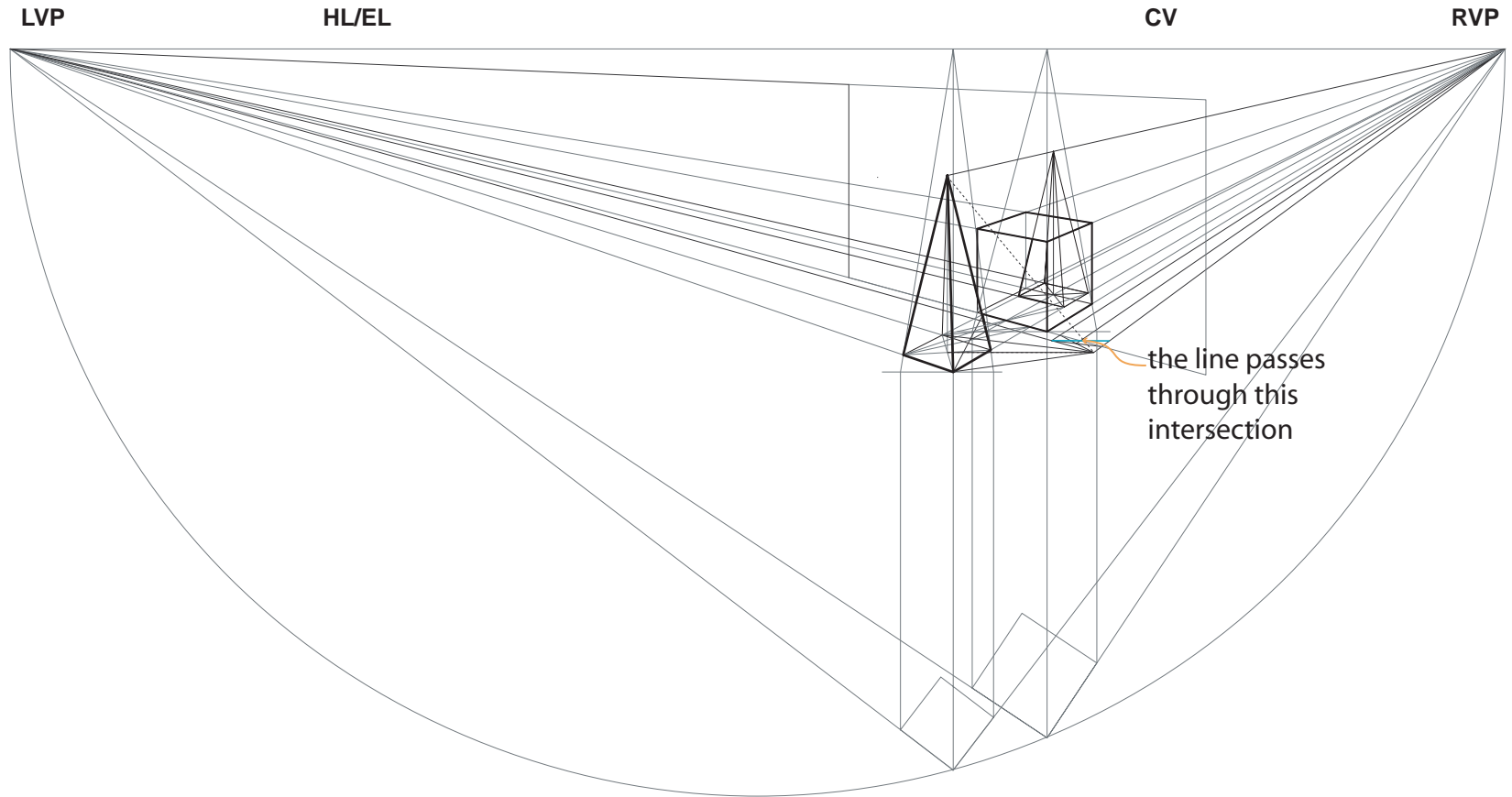

NOTES:

step 7
Draw a line from one corner through the intersection of this line with the shiny surface back to the opposite line.

HOW TO DRAFT A BASIC REFLECTION

Rebecca B. Bennett

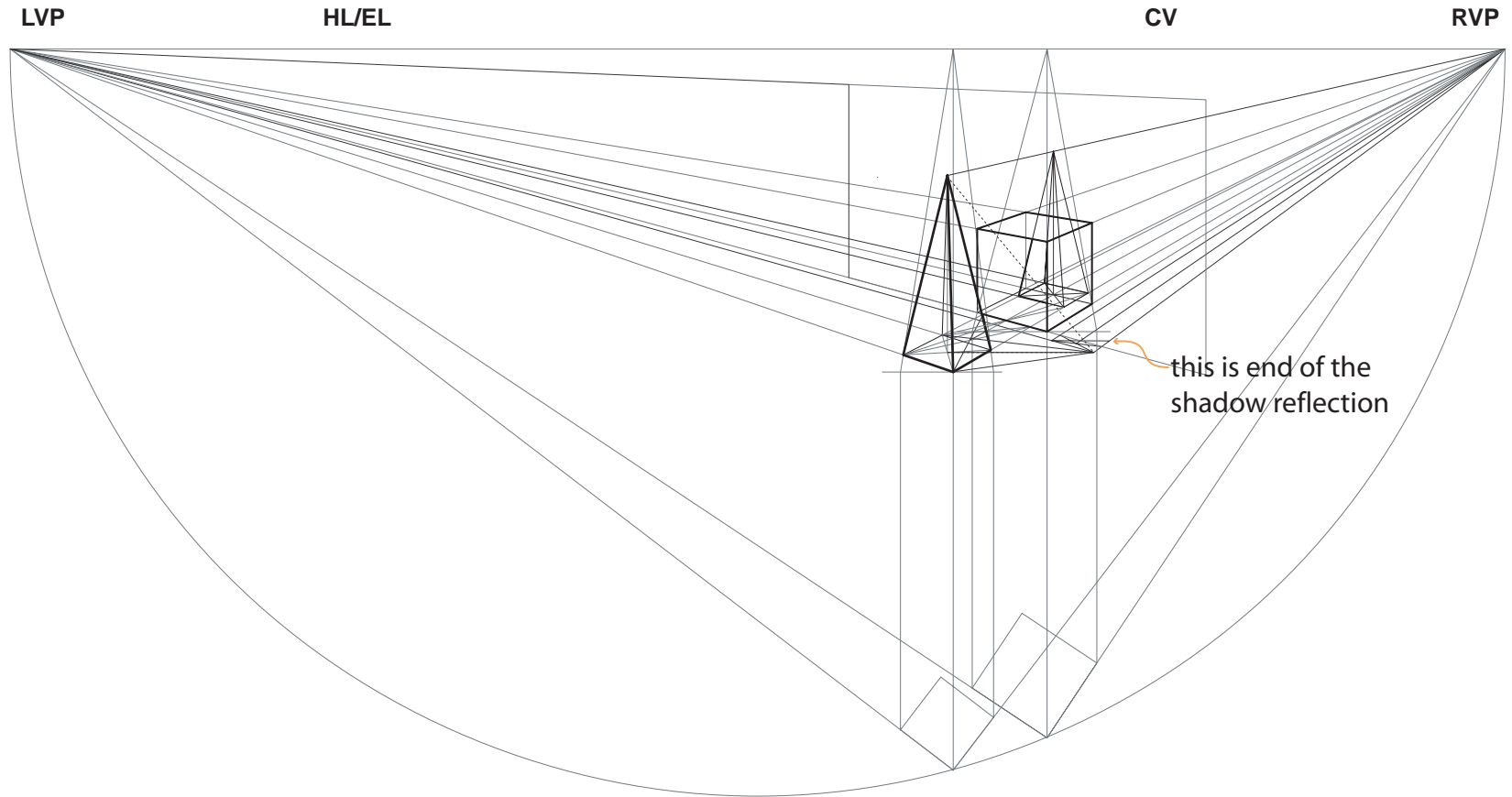

NOTES:

step 8
Locate the end of the pyramid reflection's shadow, connect it back to the pyramid

HOW TO DRAFT A BASIC REFLECTION
Rebecca B. Bennett

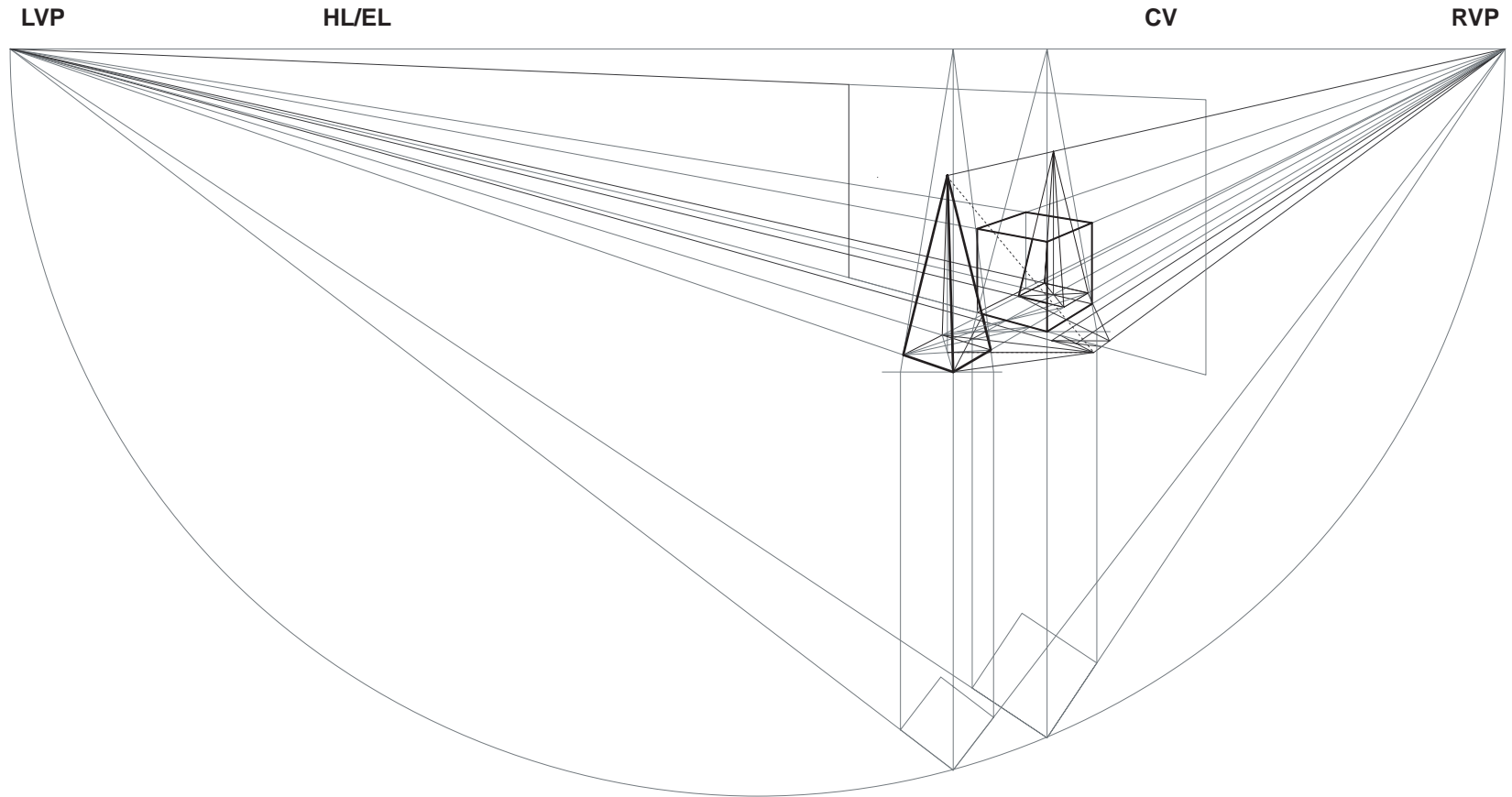

NOTES:

step 9
The reflection
only happens in
the shiny
surface