

HOW TO DRAFT A COMPLEX OBJECT

Rebecca B. Bennett

LVP

CV

HL/EL

RVP



NOTES:

step 1
Set up draft.

HOW TO DRAFT A COMPLEX OBJECT

Rebecca B. Bennett

LVP CV HL/EL RVP



NOTES:

step 2
Create elevation view on
GL.

HOW TO DRAFT A COMPLEX OBJECT

Rebecca B. Bennett

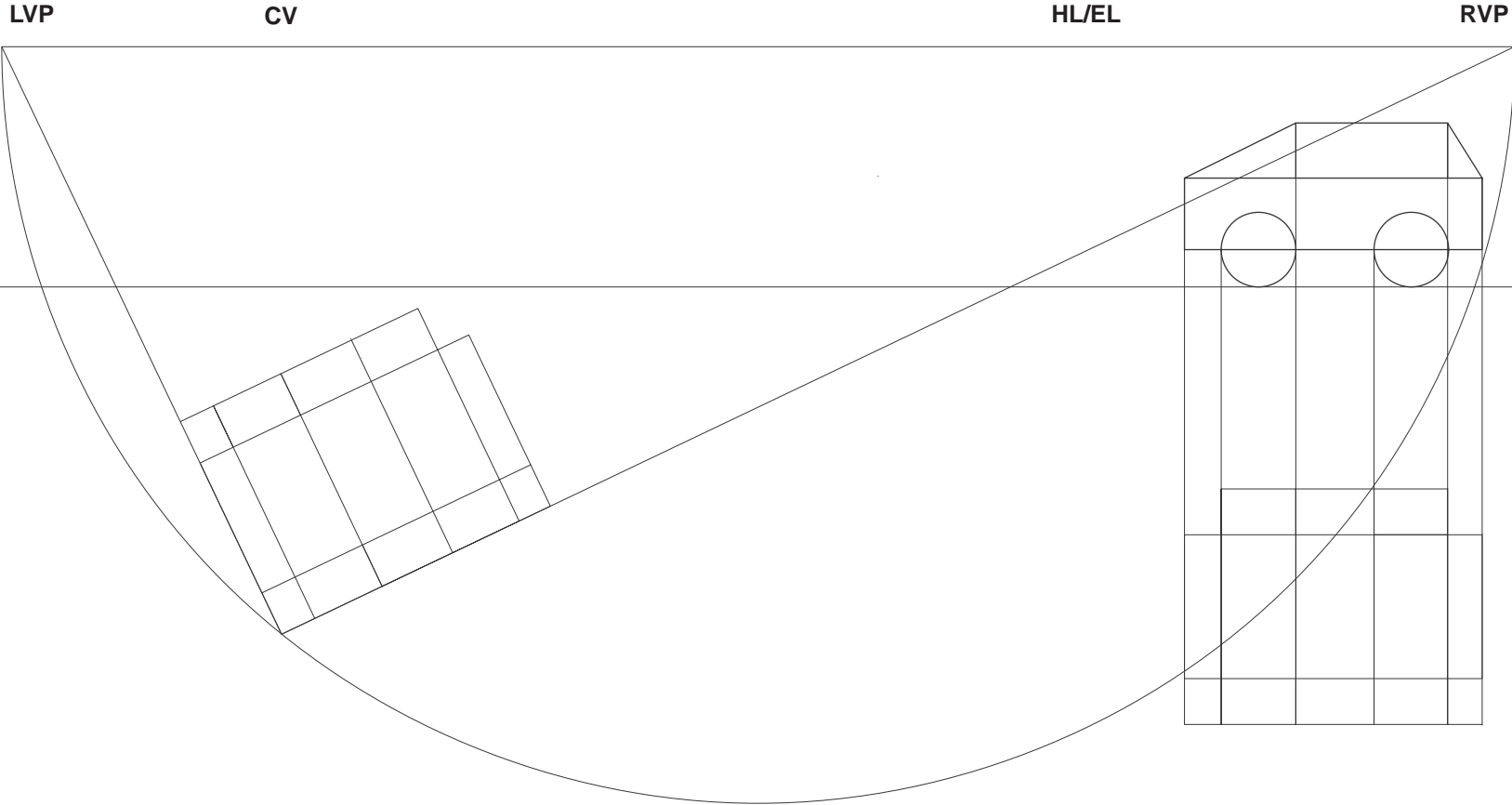

NOTES:

step 3
Create plan view

HOW TO DRAFT A COMPLEX OBJECT

Rebecca B. Bennett

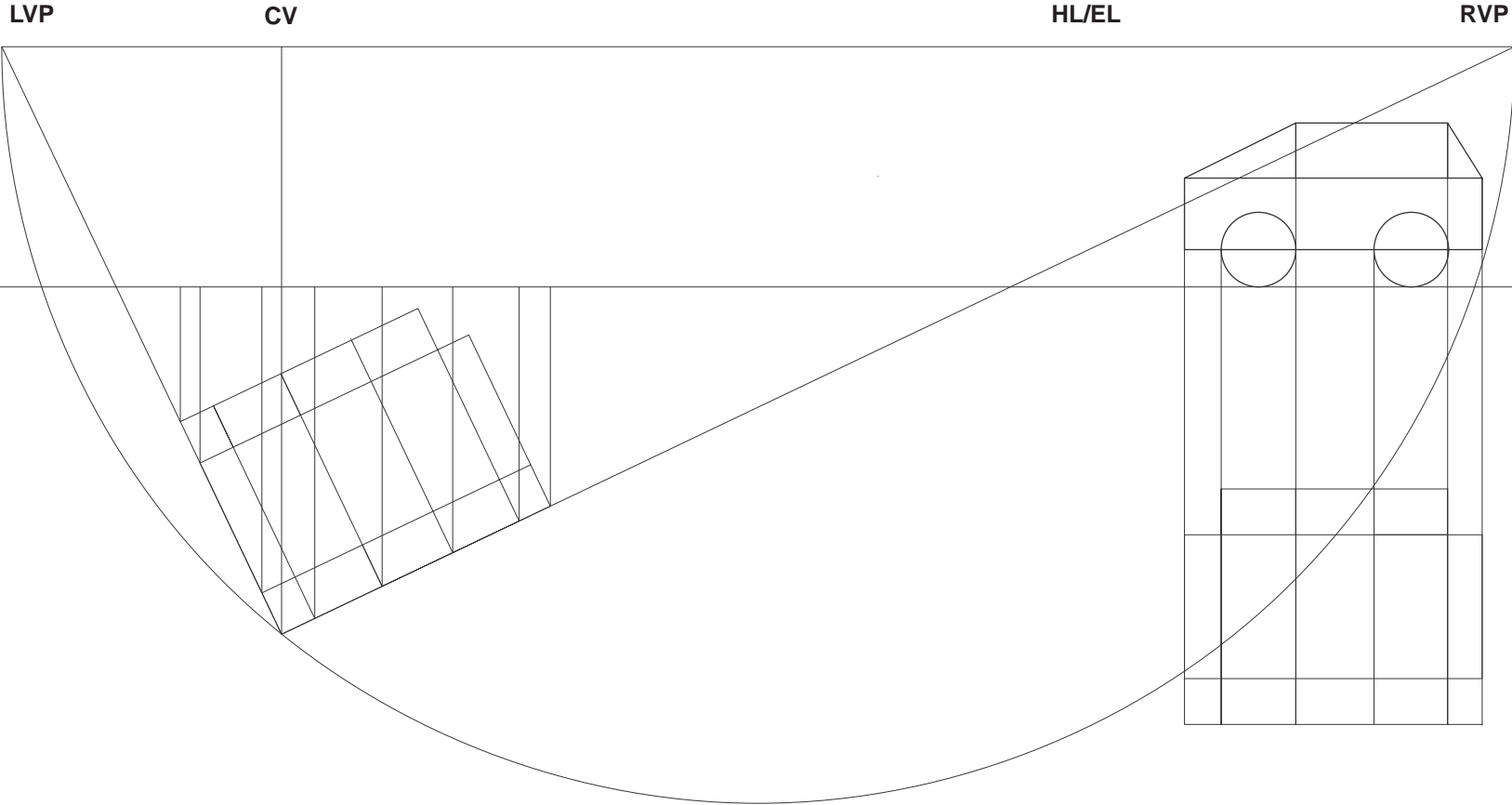

NOTES:

step 4
Bring all points from the
plan view up to the GL

HOW TO DRAFT A COMPLEX OBJECT

Rebecca B. Bennett

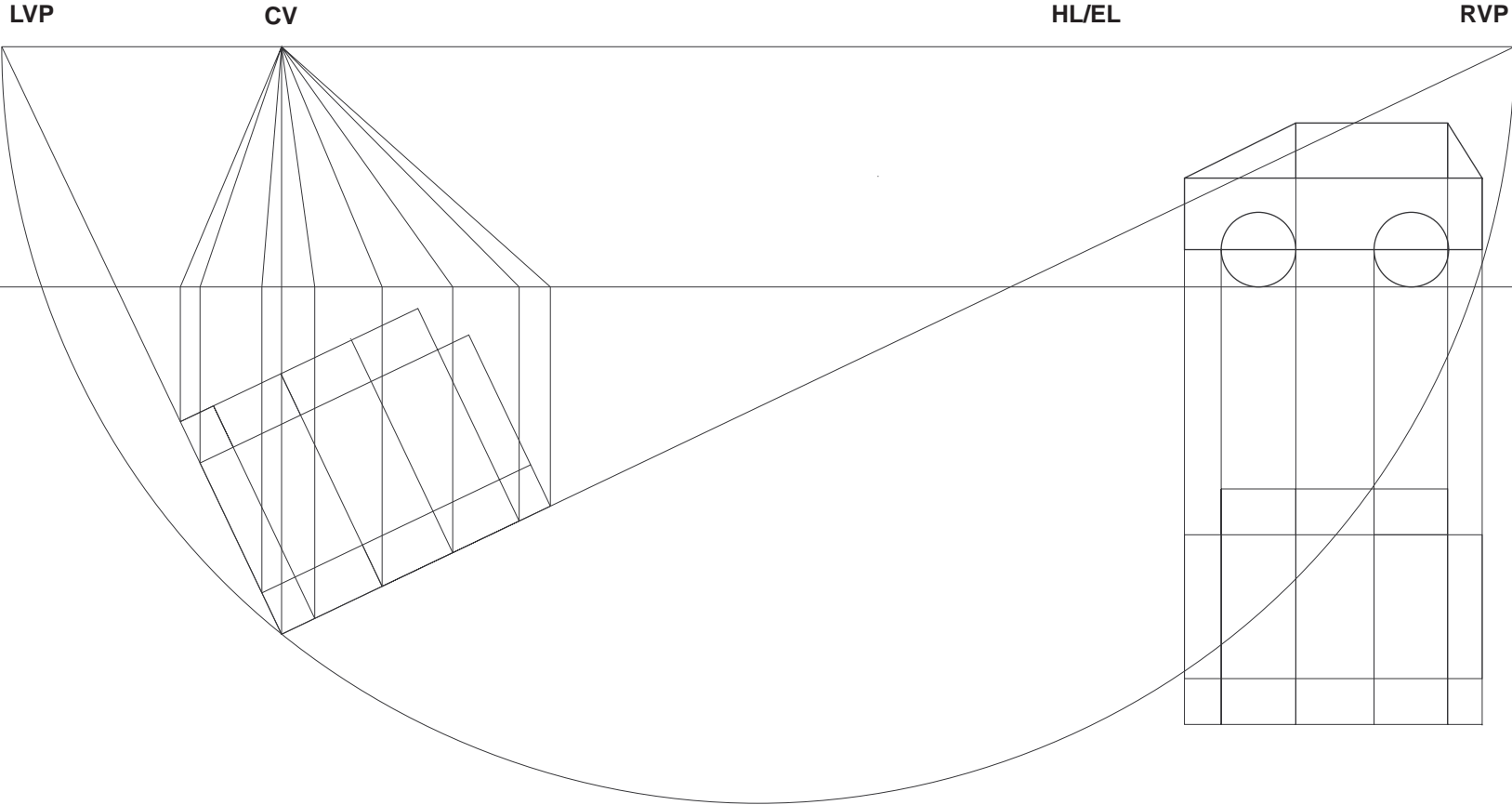

NOTES:

step 5
"Pitch the tent"

HOW TO DRAFT A COMPLEX OBJECT

Rebecca B. Bennett

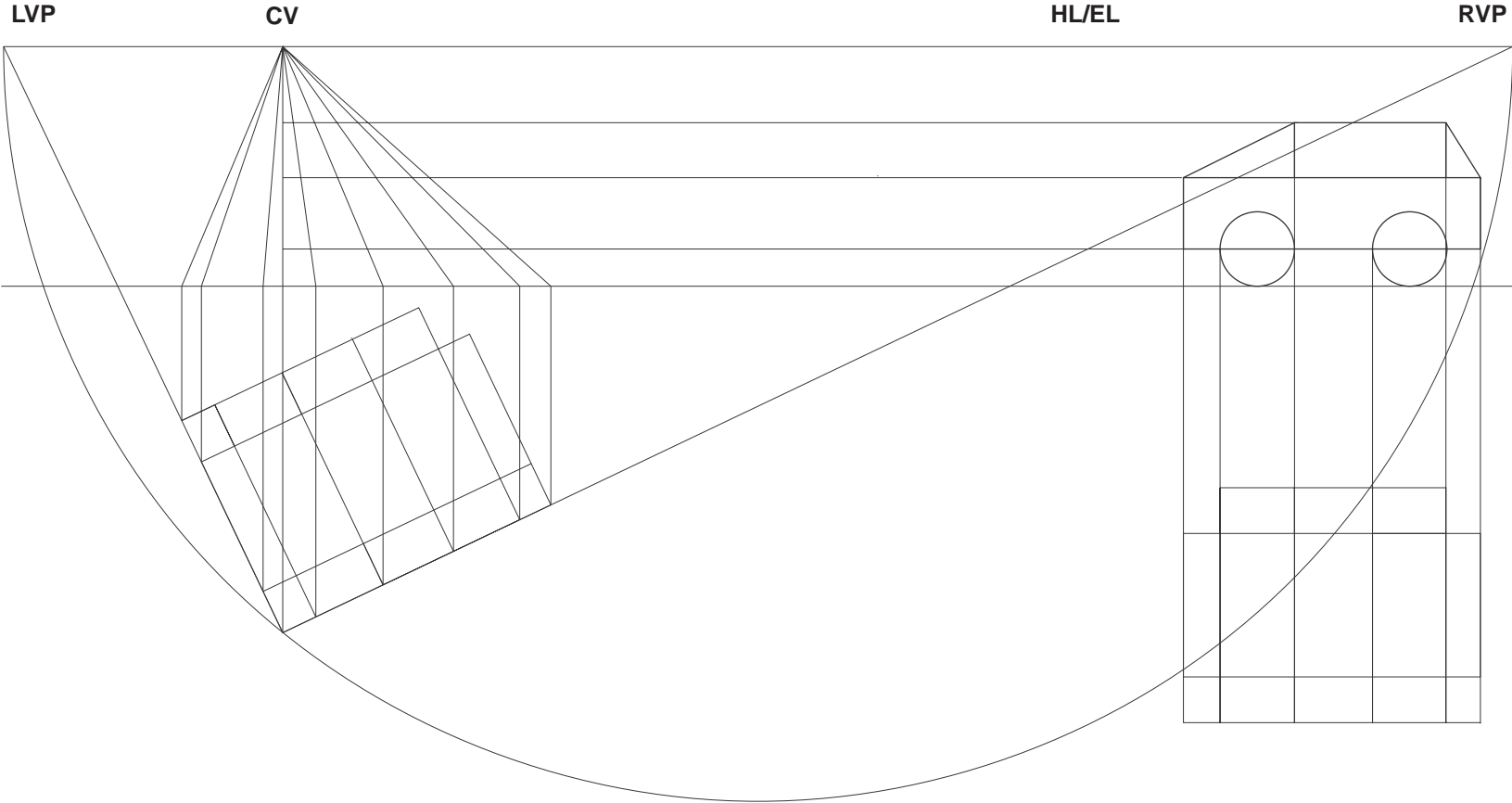

NOTES:

step 6
Bring elevation lines
across to CV line.

HOW TO DRAFT A COMPLEX OBJECT

Rebecca B. Bennett

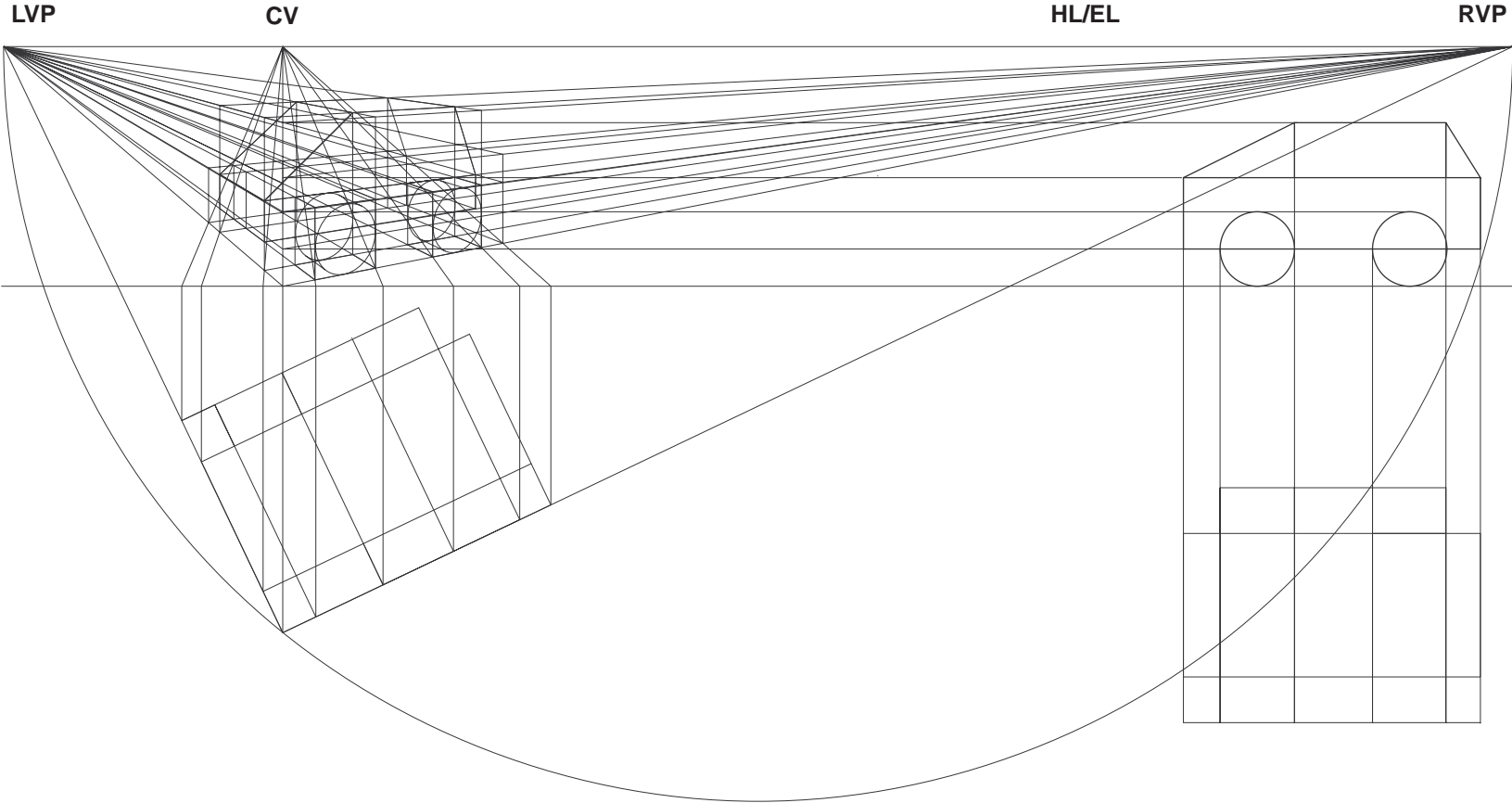

NOTES:

step 8
Build the form

HOW TO DRAFT A COMPLEX OBJECT

Rebecca B. Bennett

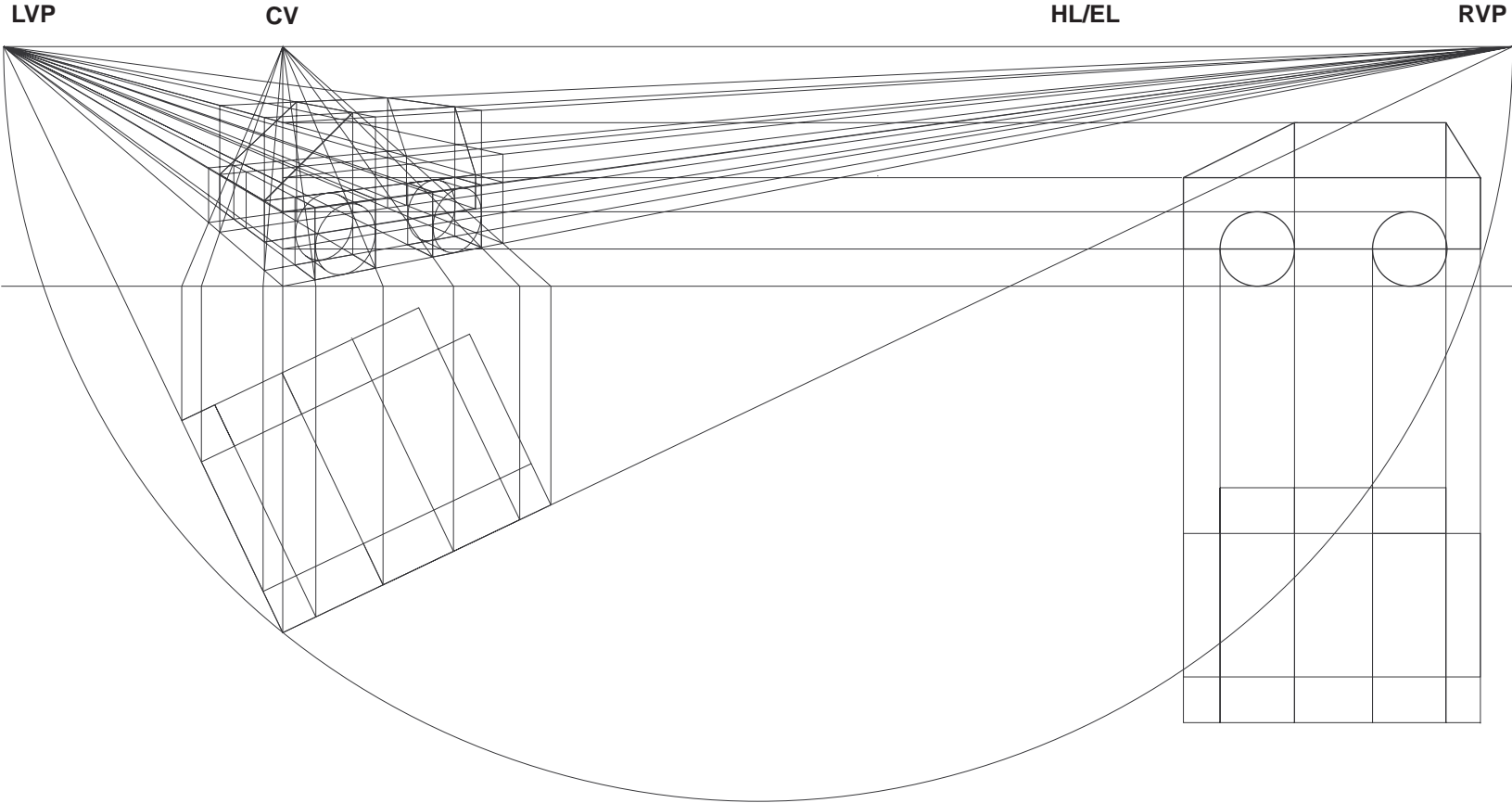

NOTES:

step 8
Build the form

HOW TO DRAFT A COMPLEX OBJECT

Rebecca B. Bennett

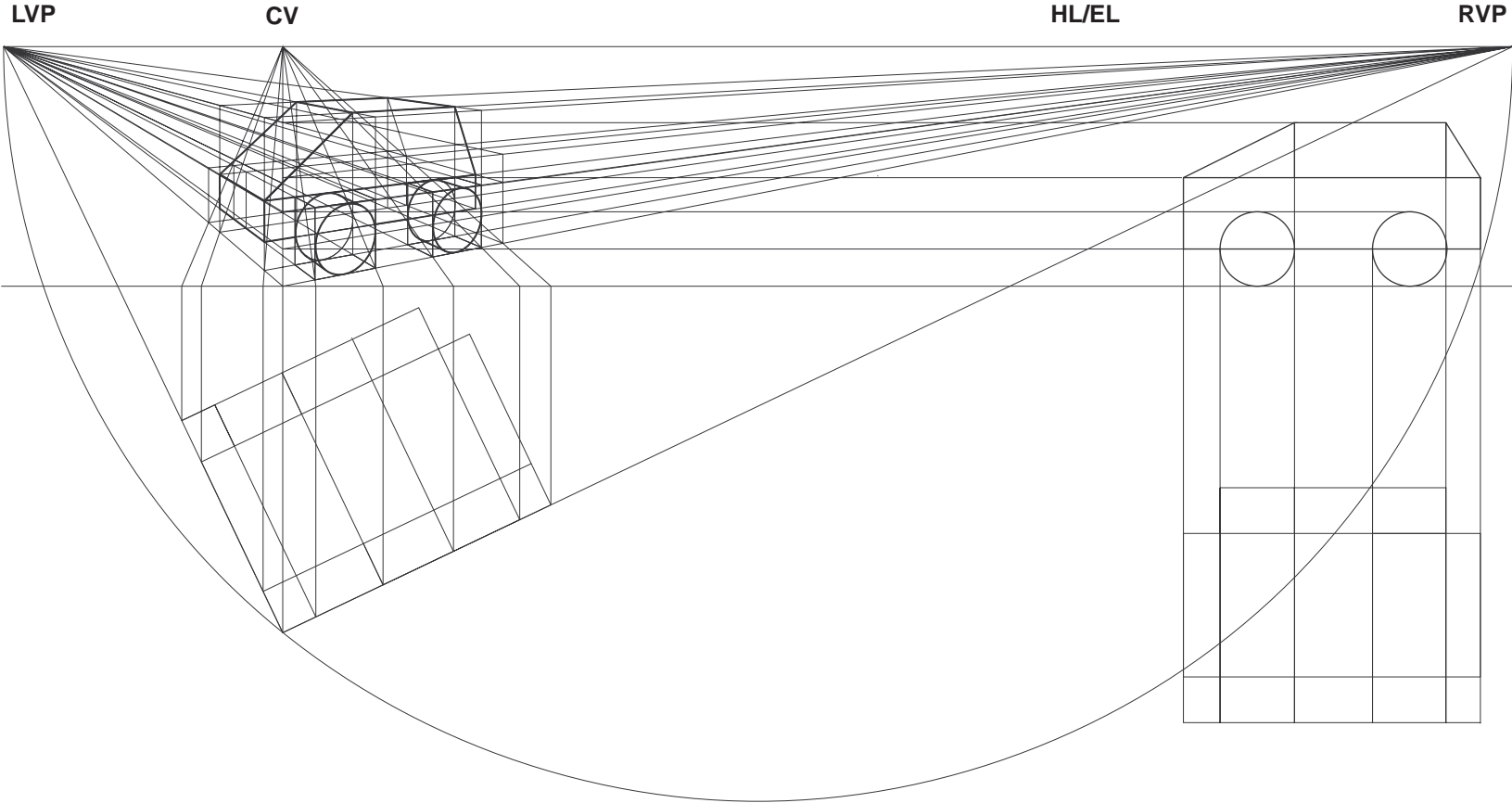

NOTES:

step 9
Adjust line weight.

