

**HOW TO DRAFT A ROLLED CYLINDER**  
Rebecca B. Bennett

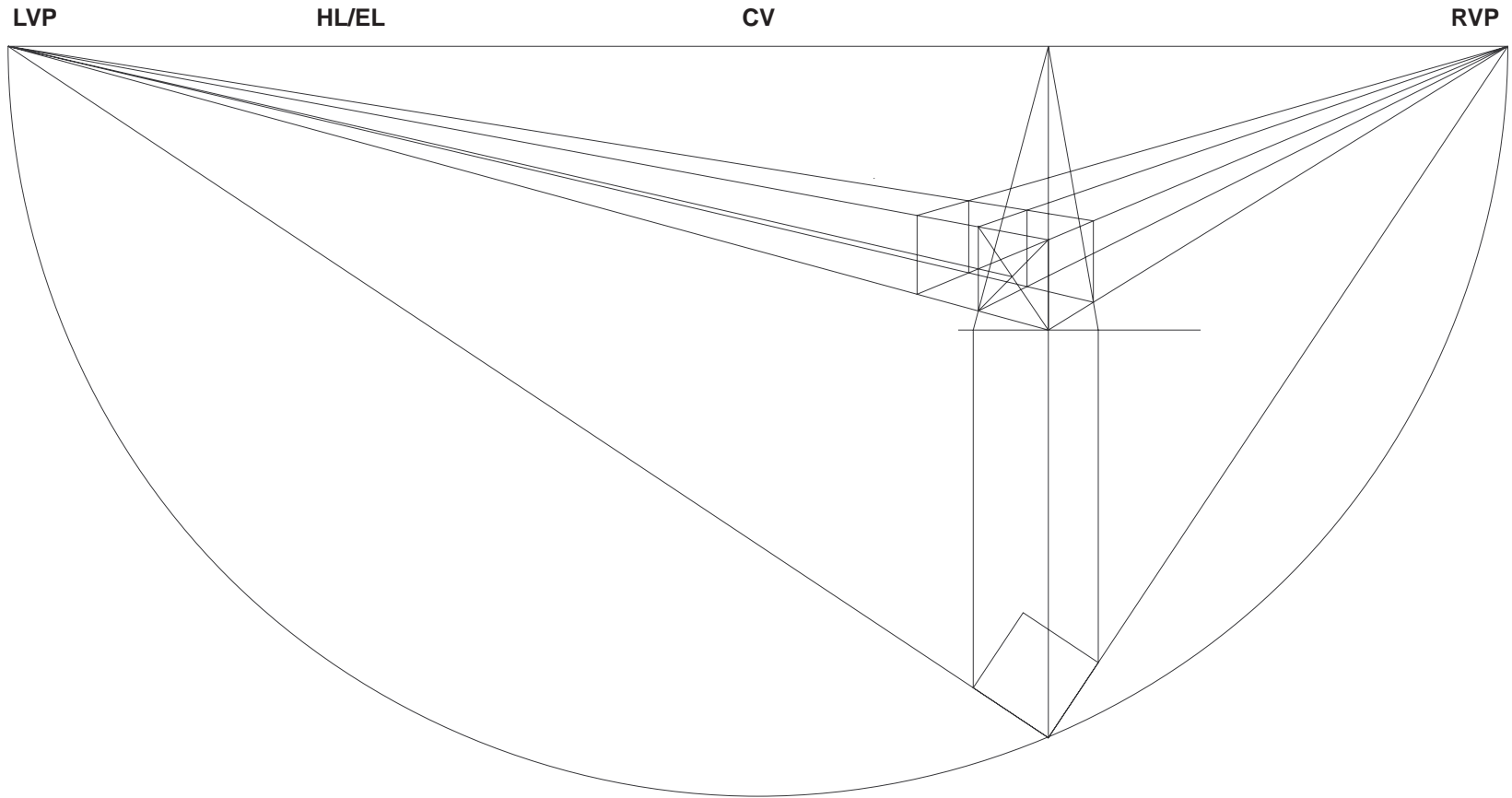

NOTES:

**step 1**  
Draft a rectangular volume in two-point perspective

**HOW TO DRAFT A ROLLED CYLINDER**  
Rebecca B. Bennett

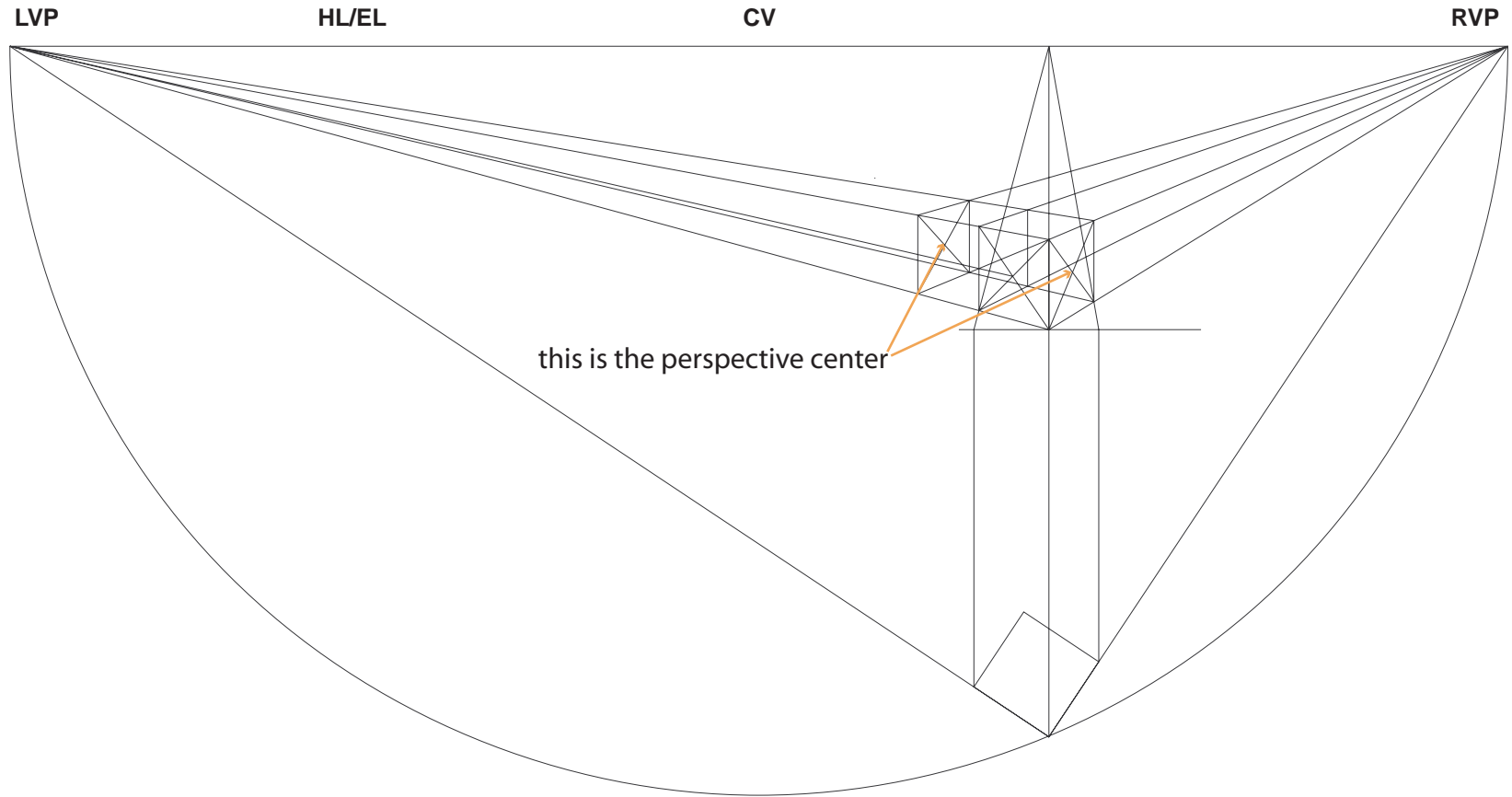

NOTES:

**step 2**  
Find the center  
of the sides that  
are squares in  
perspective

**HOW TO DRAFT A ROLLED CYLINDER**  
Rebecca B. Bennett

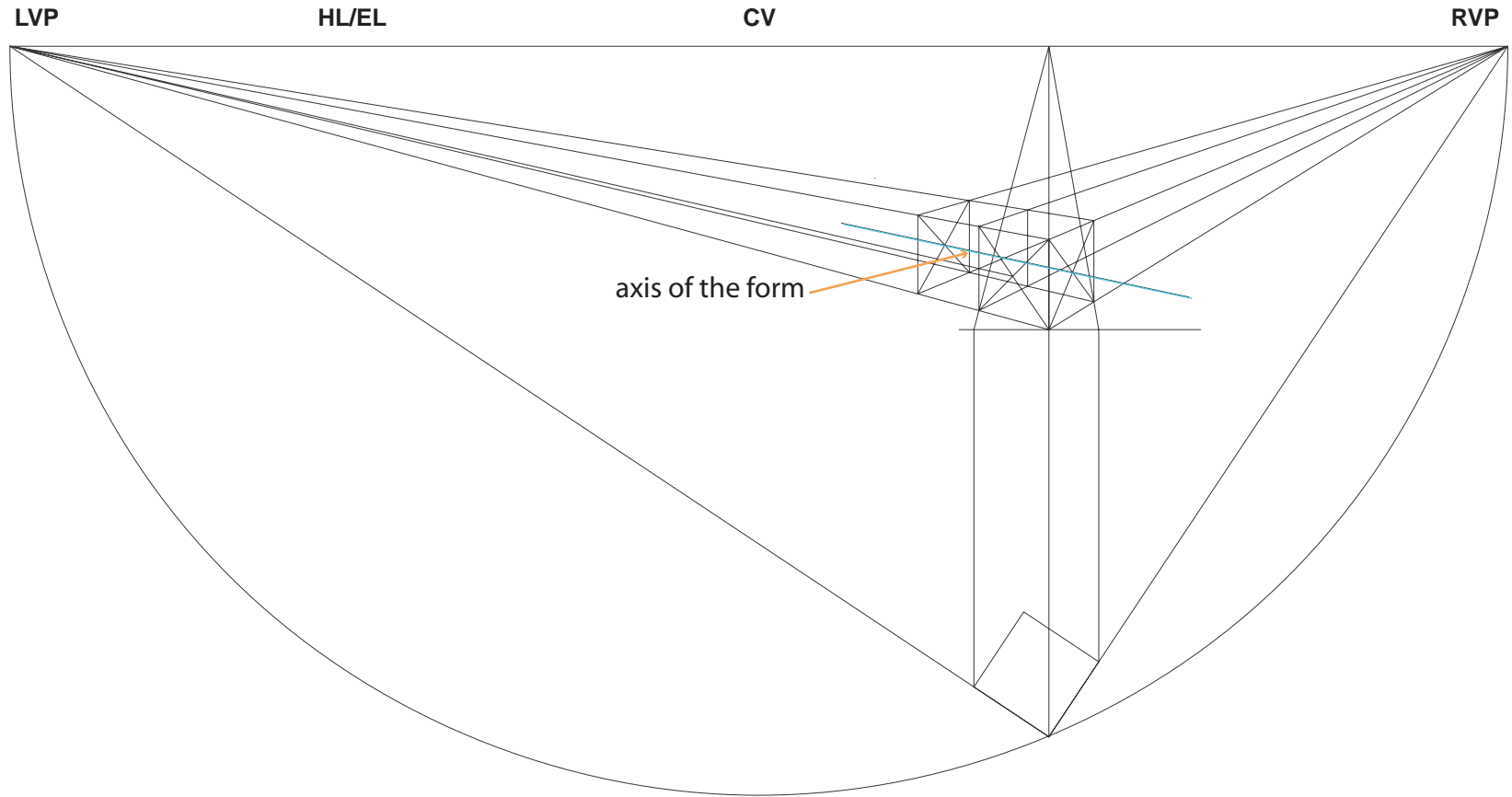

NOTES:

**step 3**  
Connect the  
centers (they  
should go back  
to the VP)

**HOW TO DRAFT A ROLLED CYLINDER**  
Rebecca B. Bennett

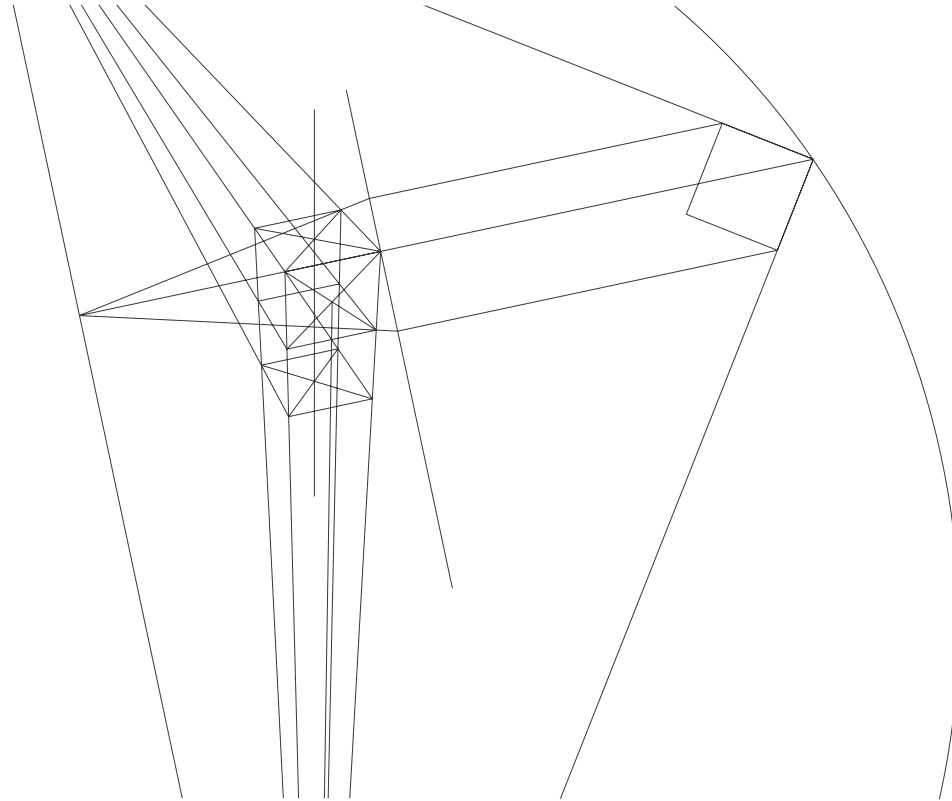

**step 4**  
Turn the paper  
so that the axis  
of the form is  
vertical

**HOW TO DRAFT A ROLLED CYLINDER**  
Rebecca B. Bennett

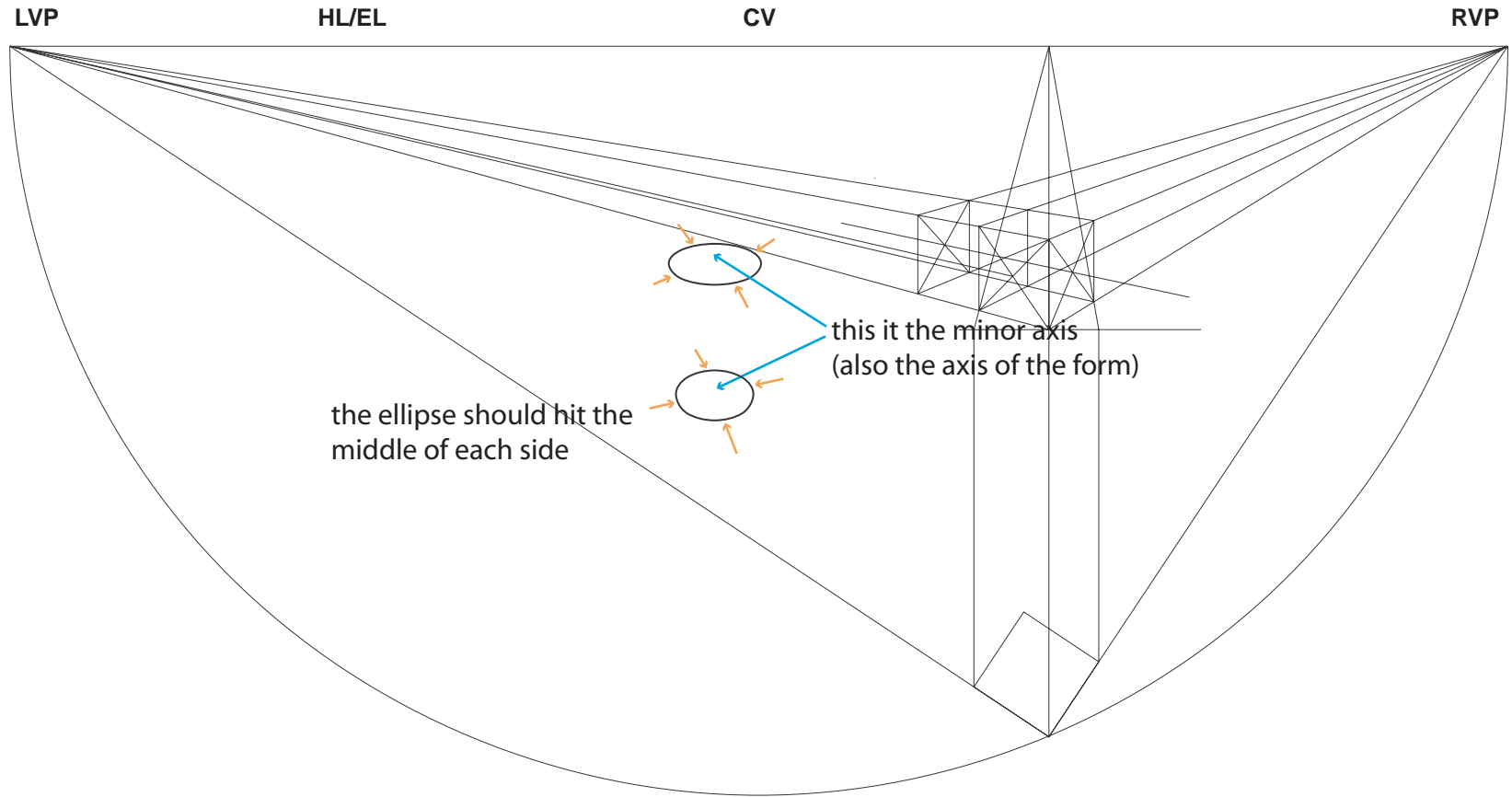

NOTES:

**step 5**  
Sketch the top  
and bottom  
ellipses

**HOW TO DRAFT A ROLLED CYLINDER**  
Rebecca B. Bennett

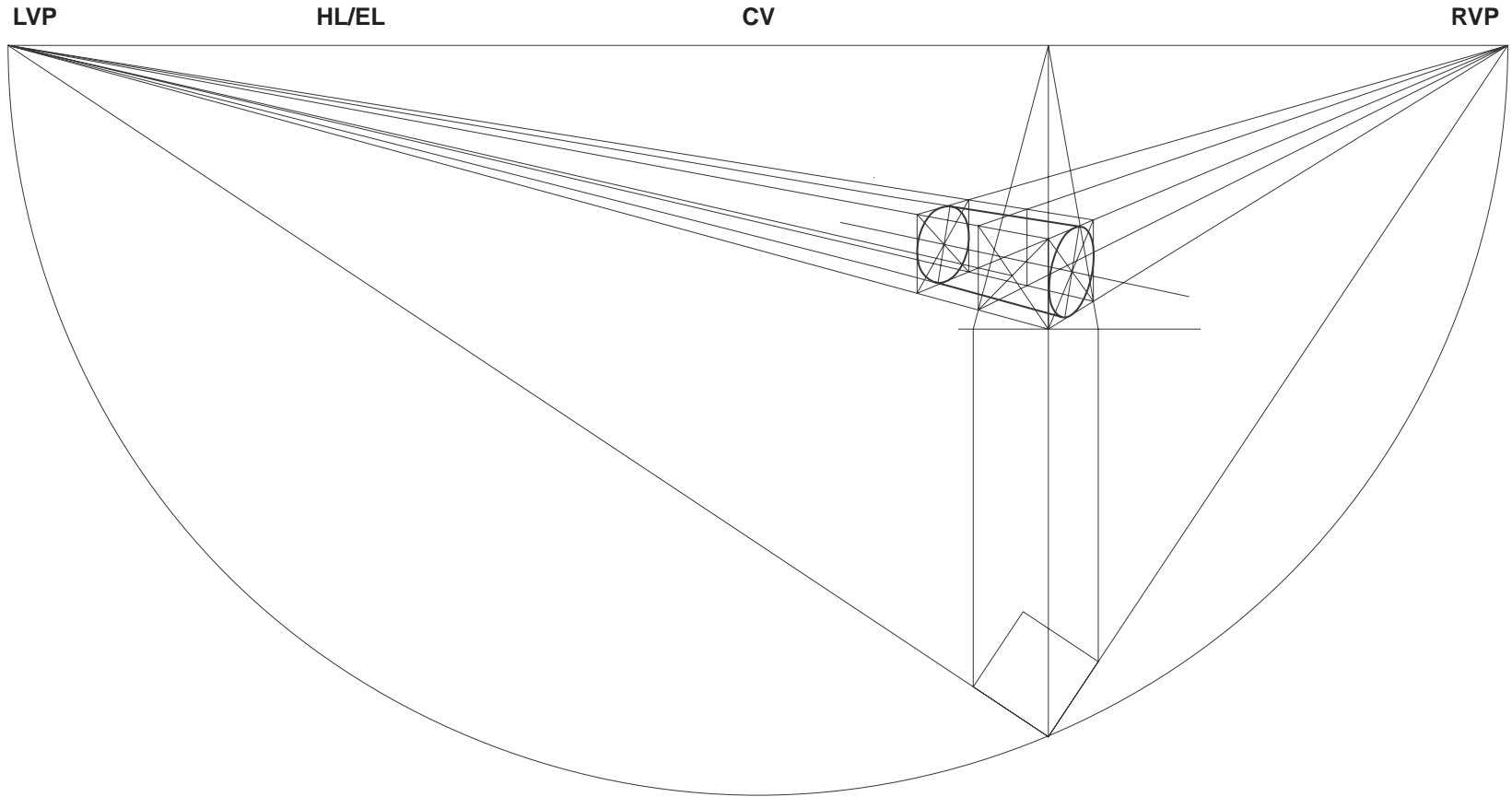

NOTES:

**step 6**  
Connect the ellipses at the major axis back to the VP

**HOW TO DRAFT A ROLLED CYLINDER**  
Rebecca B. Bennett

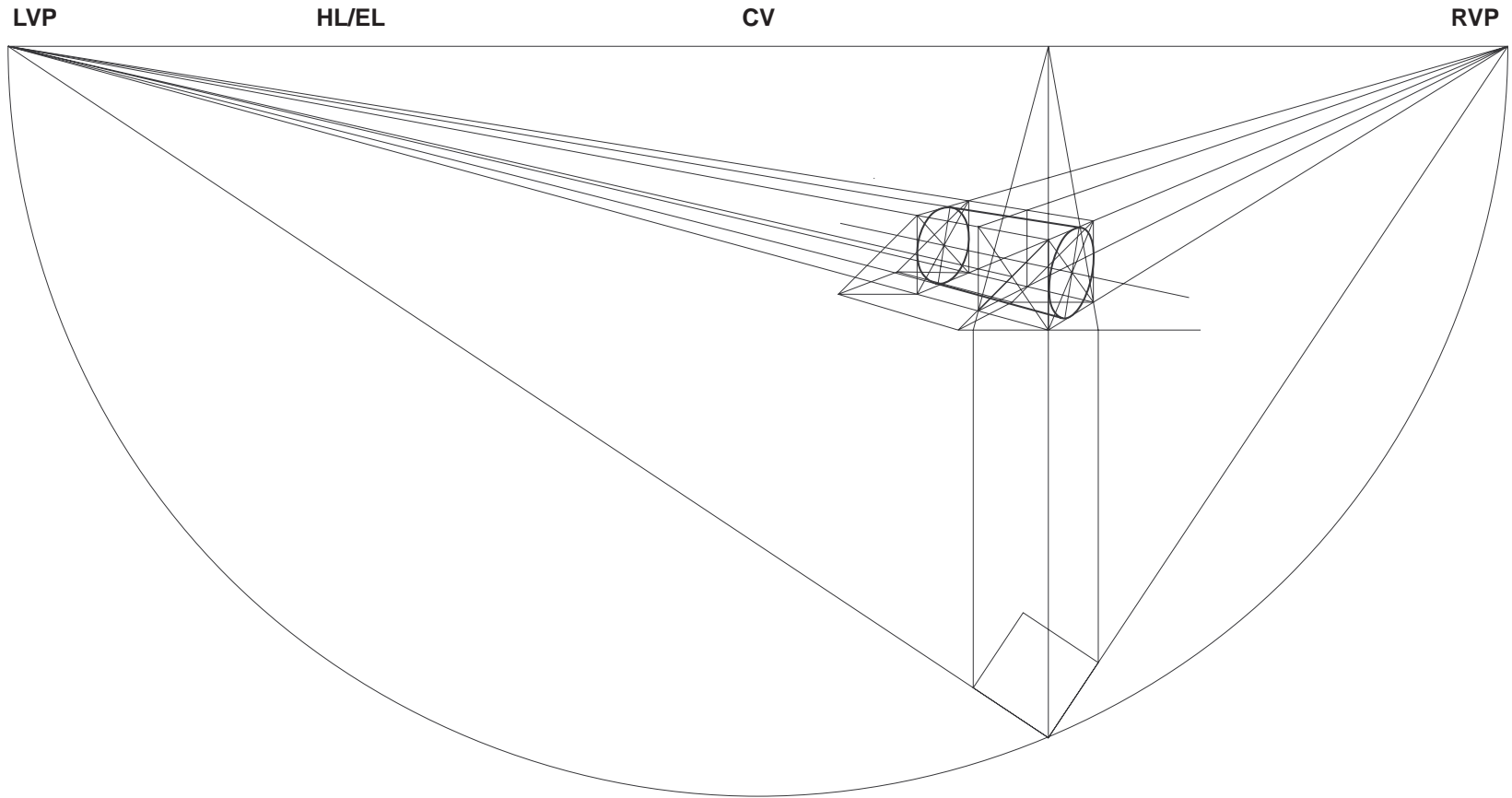

NOTES:

**step 7**  
Find the shadow  
of the rectalin-  
ear volume

**HOW TO DRAFT A ROLLED CYLINDER**  
Rebecca B. Bennett

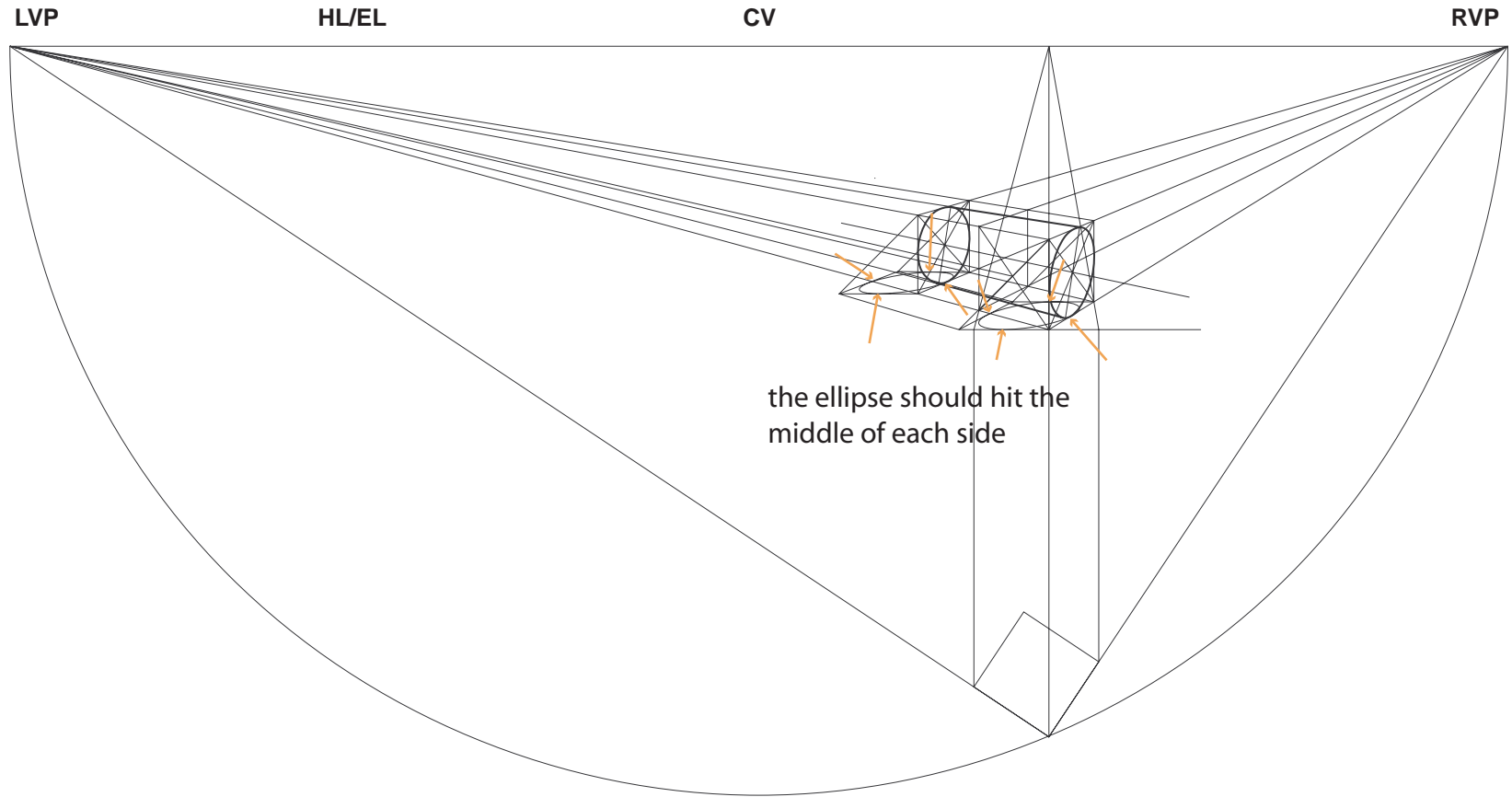

NOTES:

**step 8**  
Sketch the ellipses in the shadow of the rectilinear volume

**HOW TO DRAFT A ROLLED CYLINDER**  
Rebecca B. Bennett

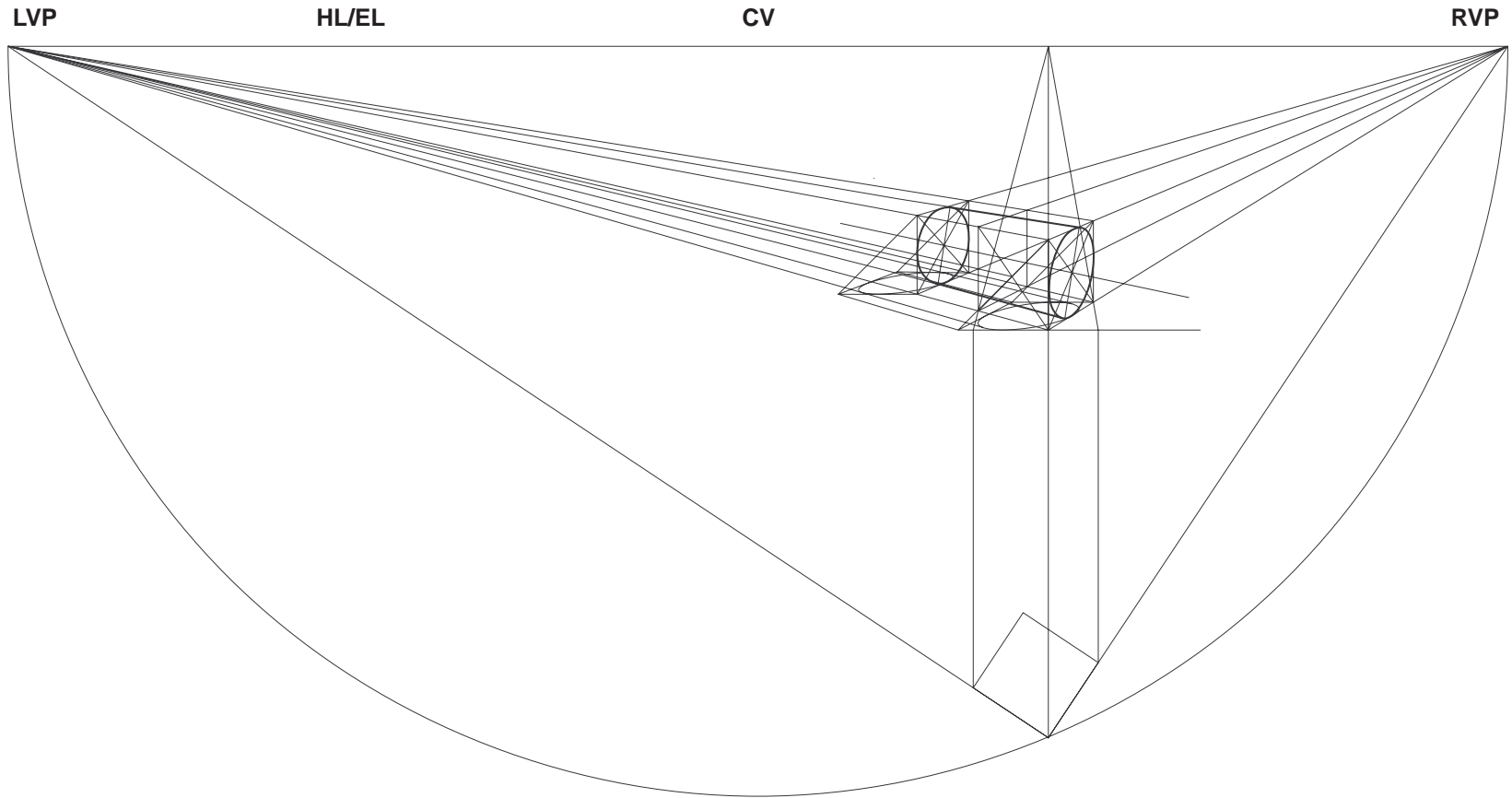

NOTES:

**step 9**  
Connect these  
together and  
send them back  
to the VP

**HOW TO DRAFT A ROLLED CYLINDER**  
Rebecca B. Bennett

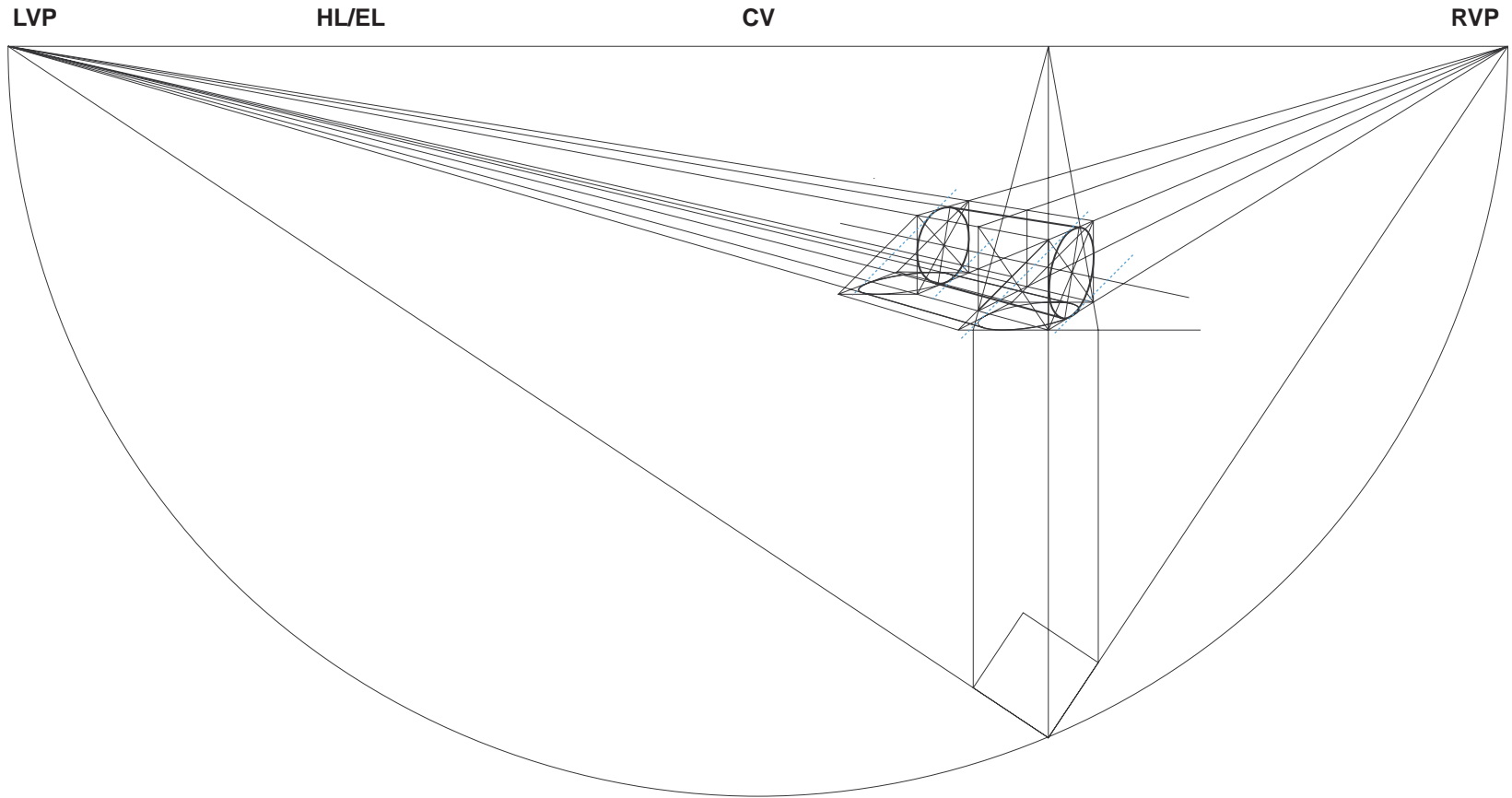

NOTES:

**step 10**  
Using the  
altitude, check  
the shadow

**HOW TO DRAFT A ROLLED CYLINDER**  
Rebecca B. Bennett

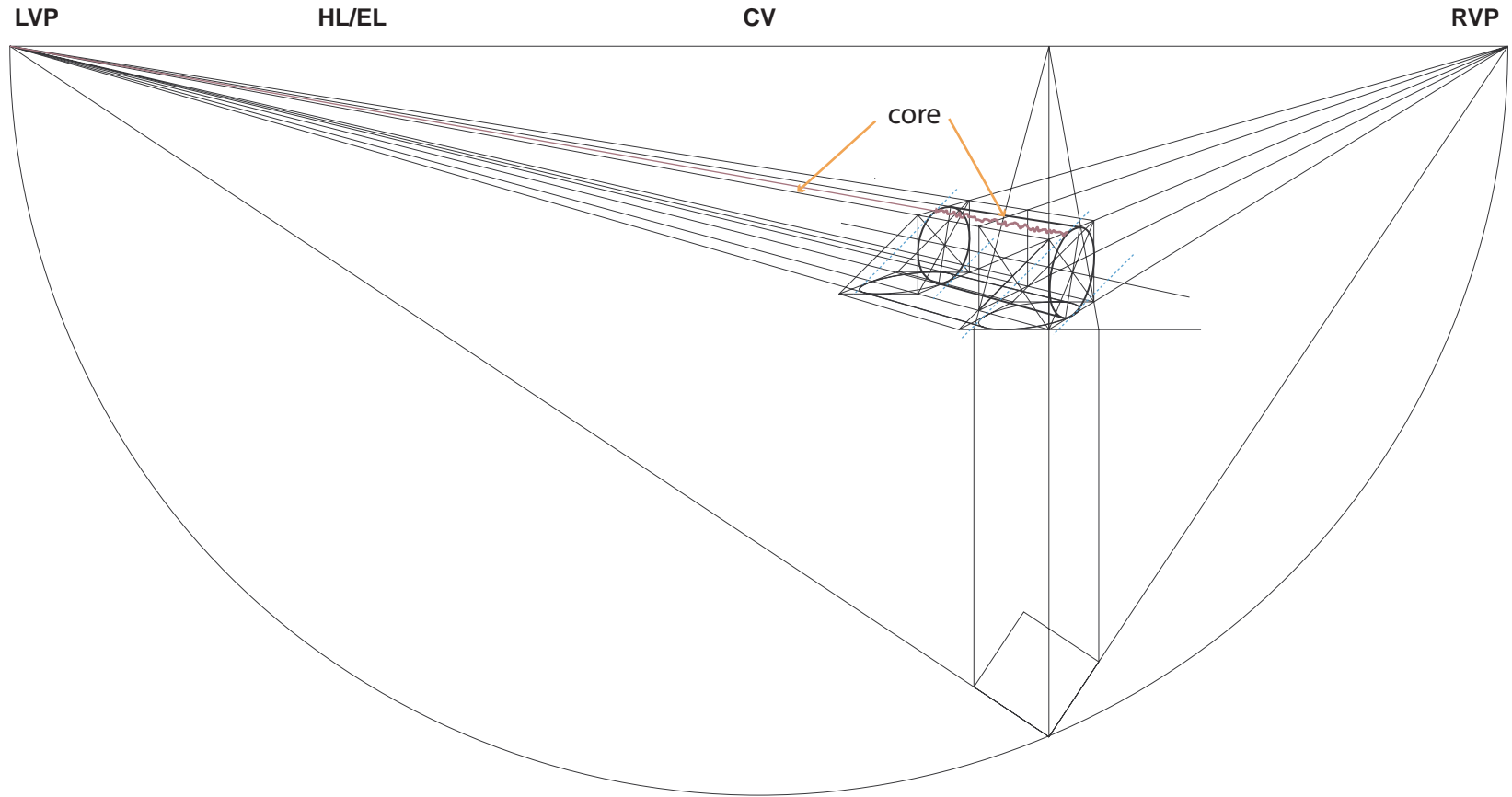

NOTES:

**step 11**  
Mark where the altitude is tangent to the ellipse. Connect these two tangencies back to the VP. This is the core.

