

**HOW TO DRAFT A STANDING CYLINDER**

Rebecca B. Bennett

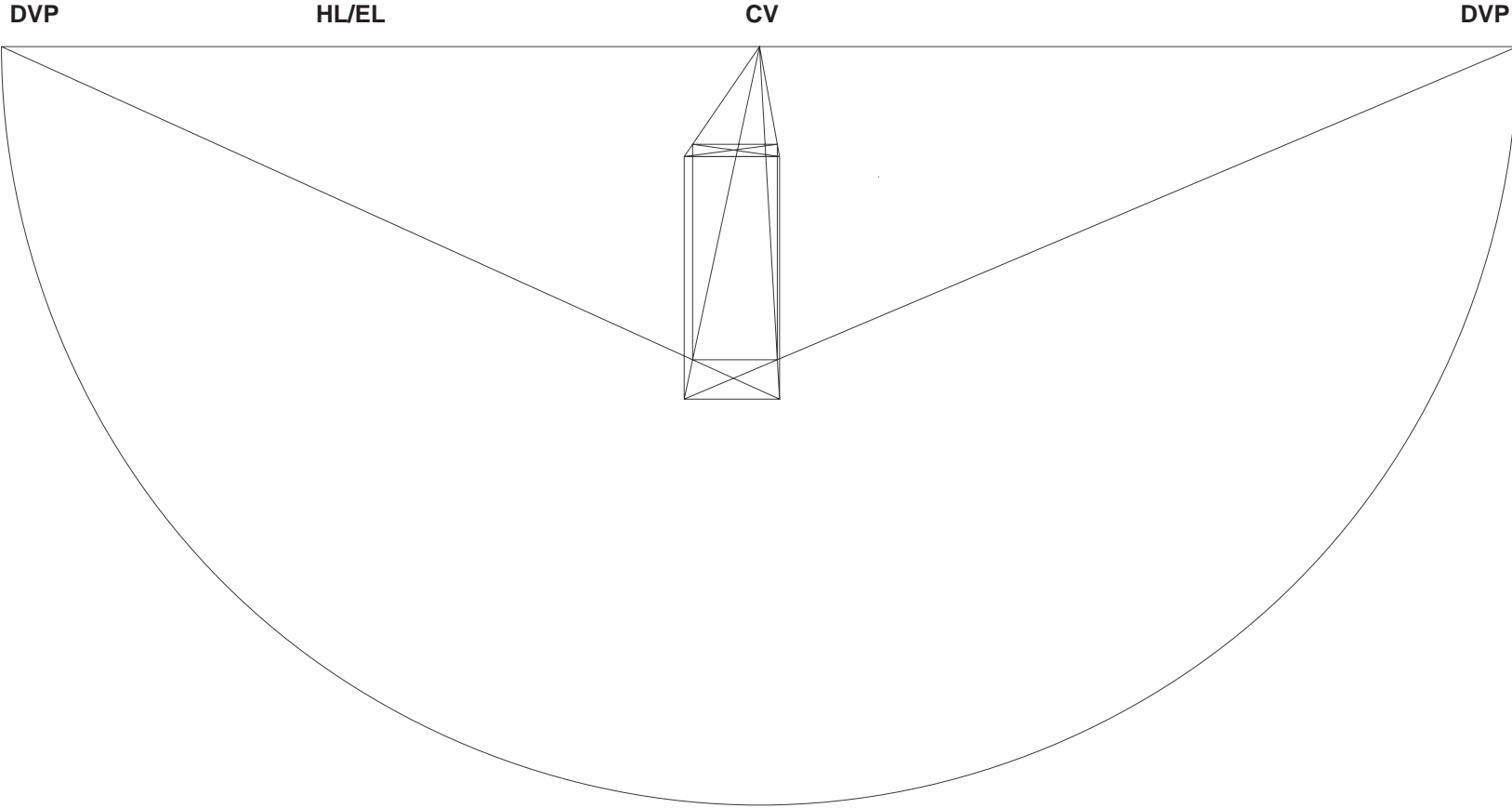

NOTES:

**step 1**  
Draft a rectilinear volume in one-point perspective so that the bases are both squares in perspective

**HOW TO DRAFT A STANDING CYLINDER**

Rebecca B. Bennett

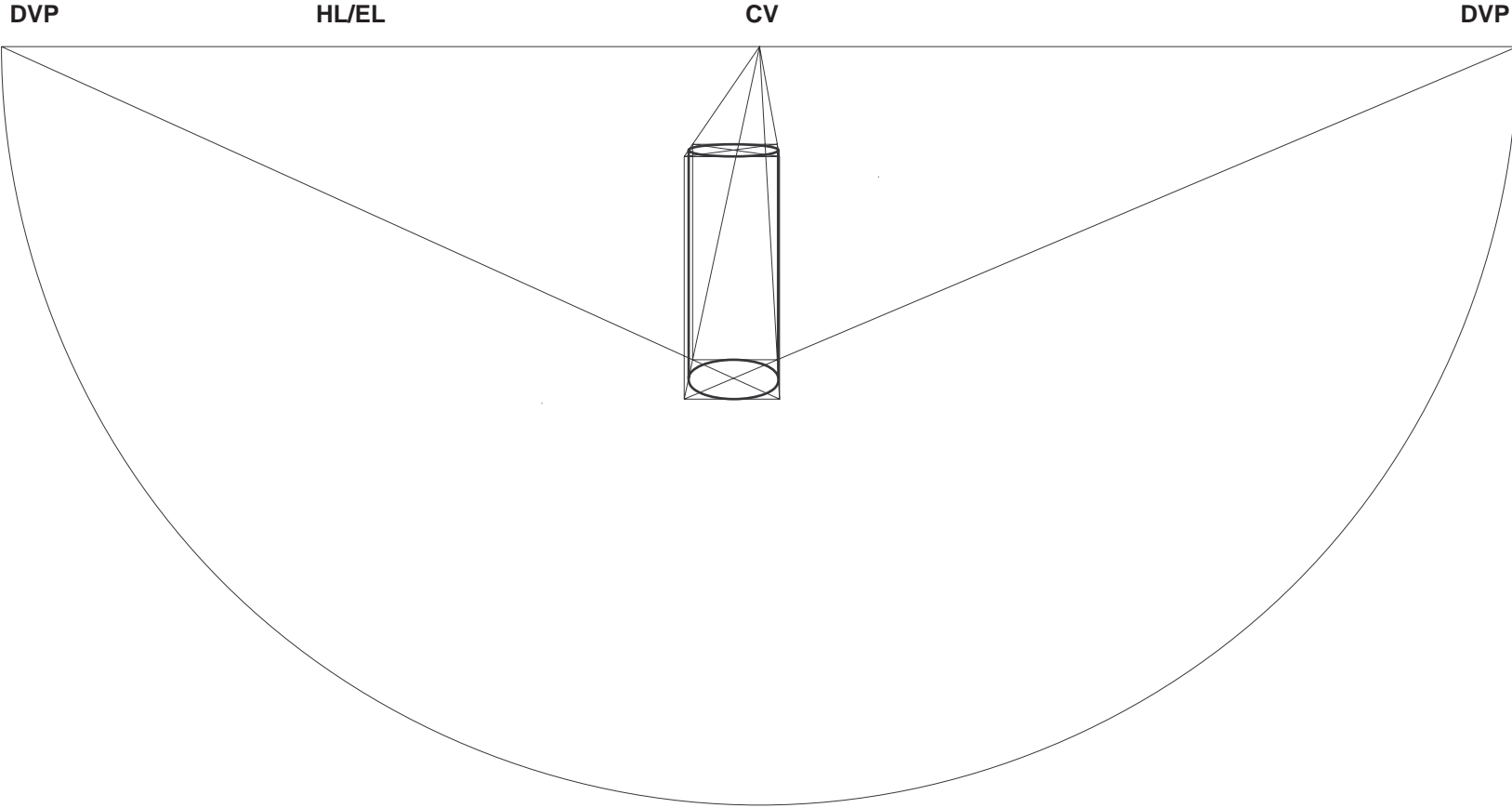

NOTES:

**step 2**  
Sketch in the  
bottom and top  
ellipses and  
connect up  
the sides

**HOW TO DRAFT A STANDING CYLINDER**

Rebecca B. Bennett

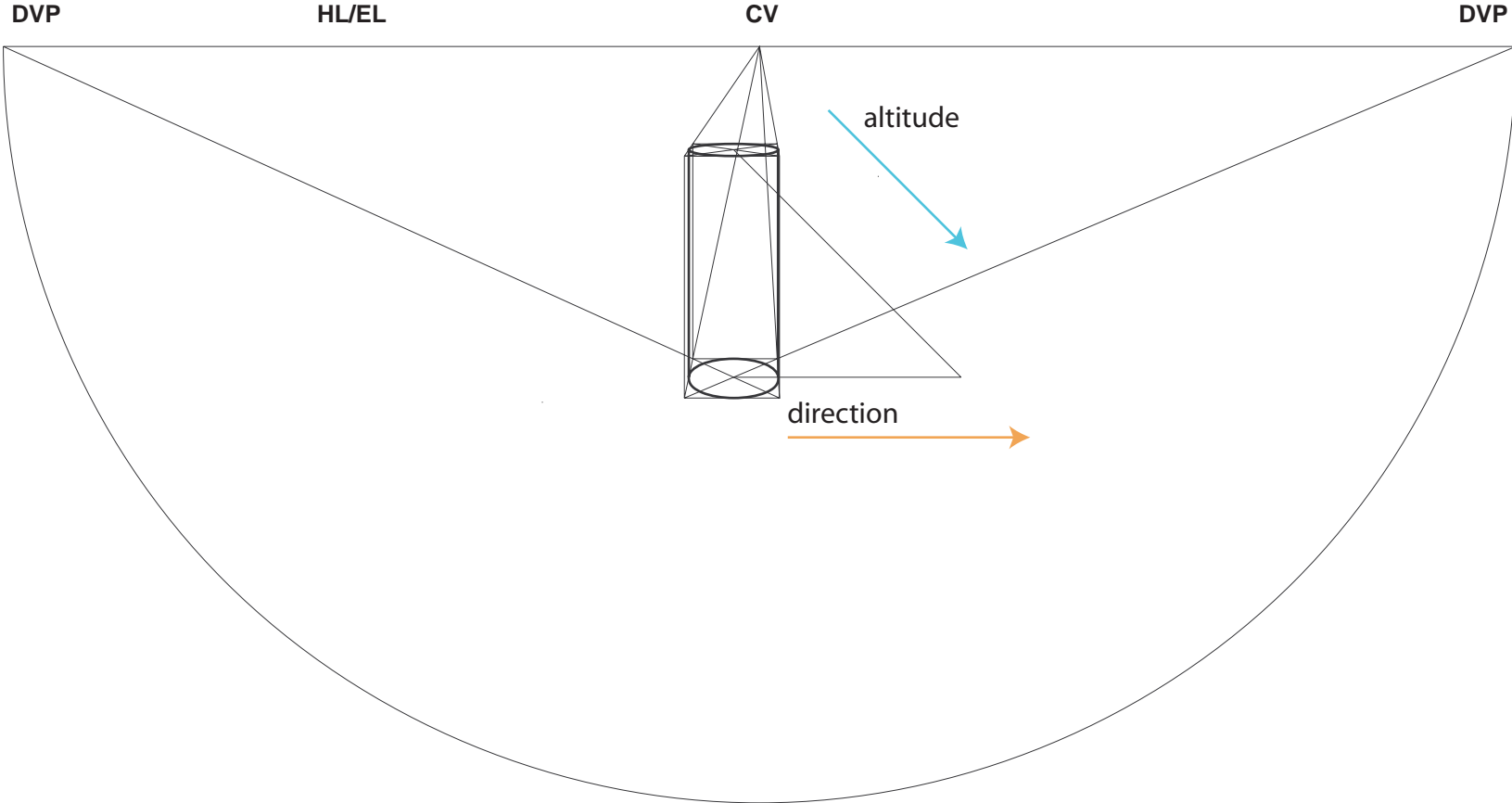

NOTES:

**step 3**  
Extend the direction through the center of the base and to the side and draw the altitude from the center of the top ellipse to the direction line

**HOW TO DRAFT A STANDING CYLINDER**

Rebecca B. Bennett

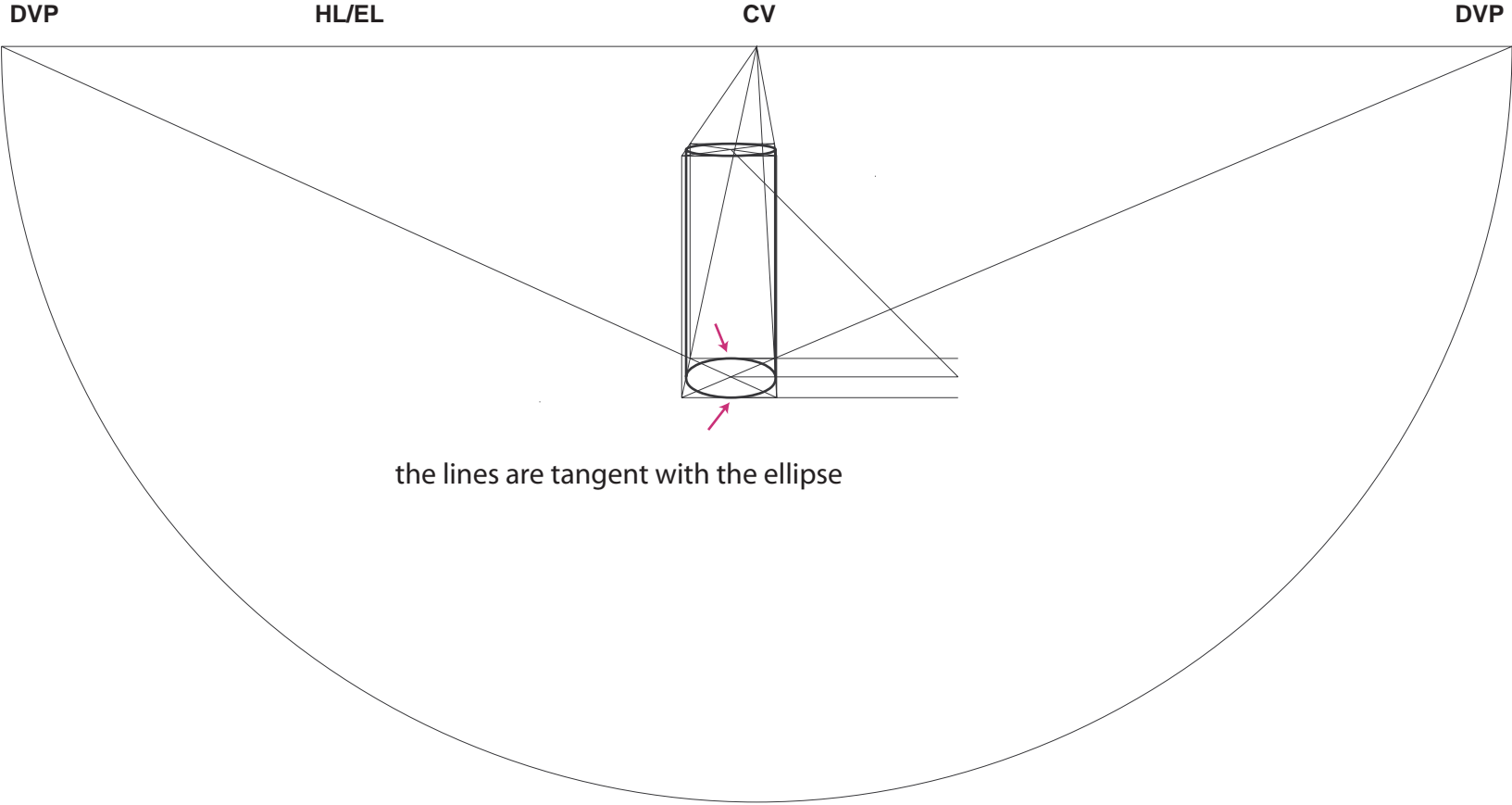

NOTES:

**step 4**  
Draft lines  
parallel to the  
direction and  
tangent with the  
base ellipse

**HOW TO DRAFT A STANDING CYLINDER**

Rebecca B. Bennett

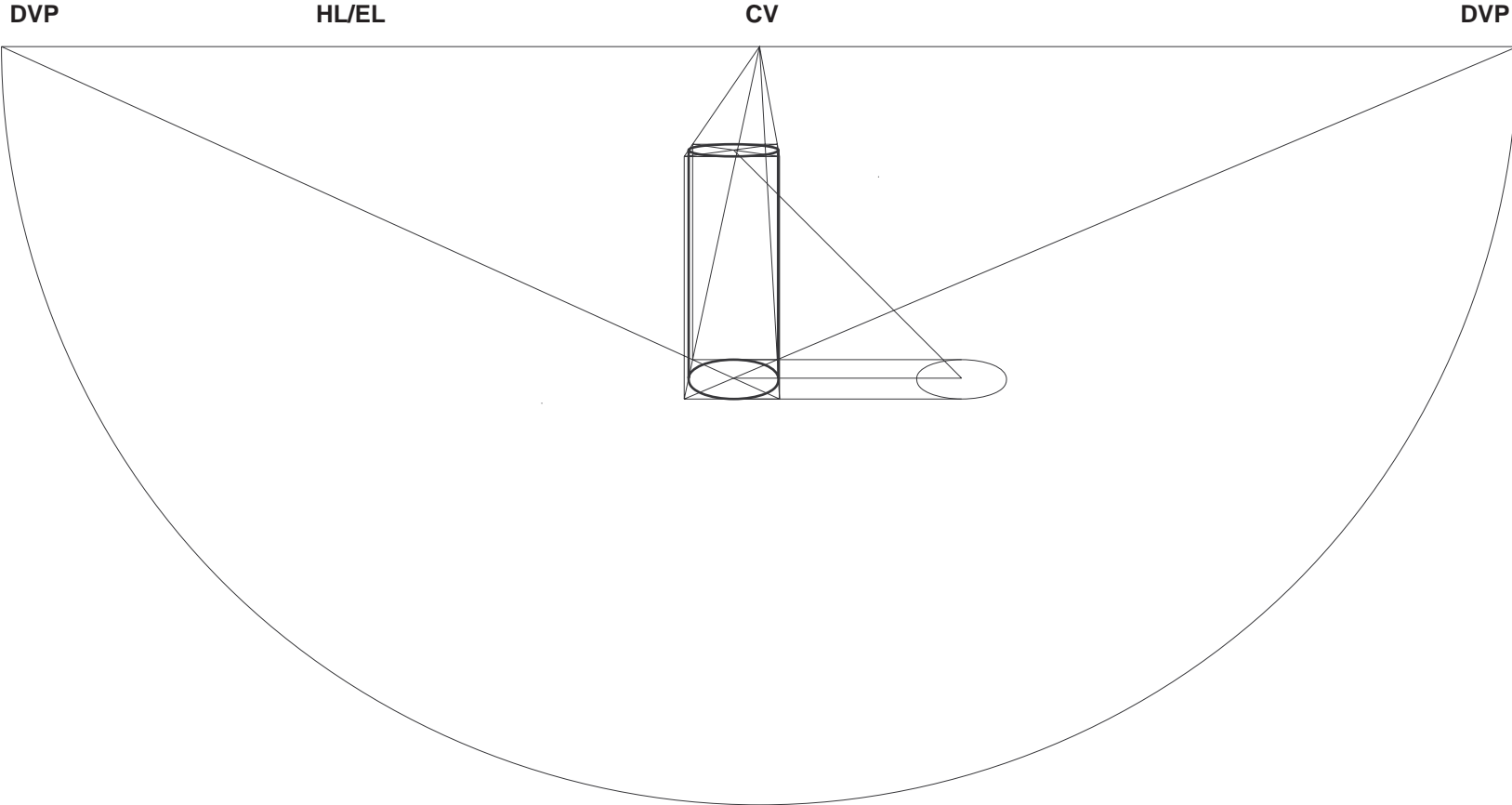

NOTES:

**step 5**  
Make an ellipse that's major axis is parallel to the H/EL, whose center is the intersection of the altitude and direction, and that is tangent with the lines from step 5

**HOW TO DRAFT A STANDING CYLINDER**

Rebecca B. Bennett

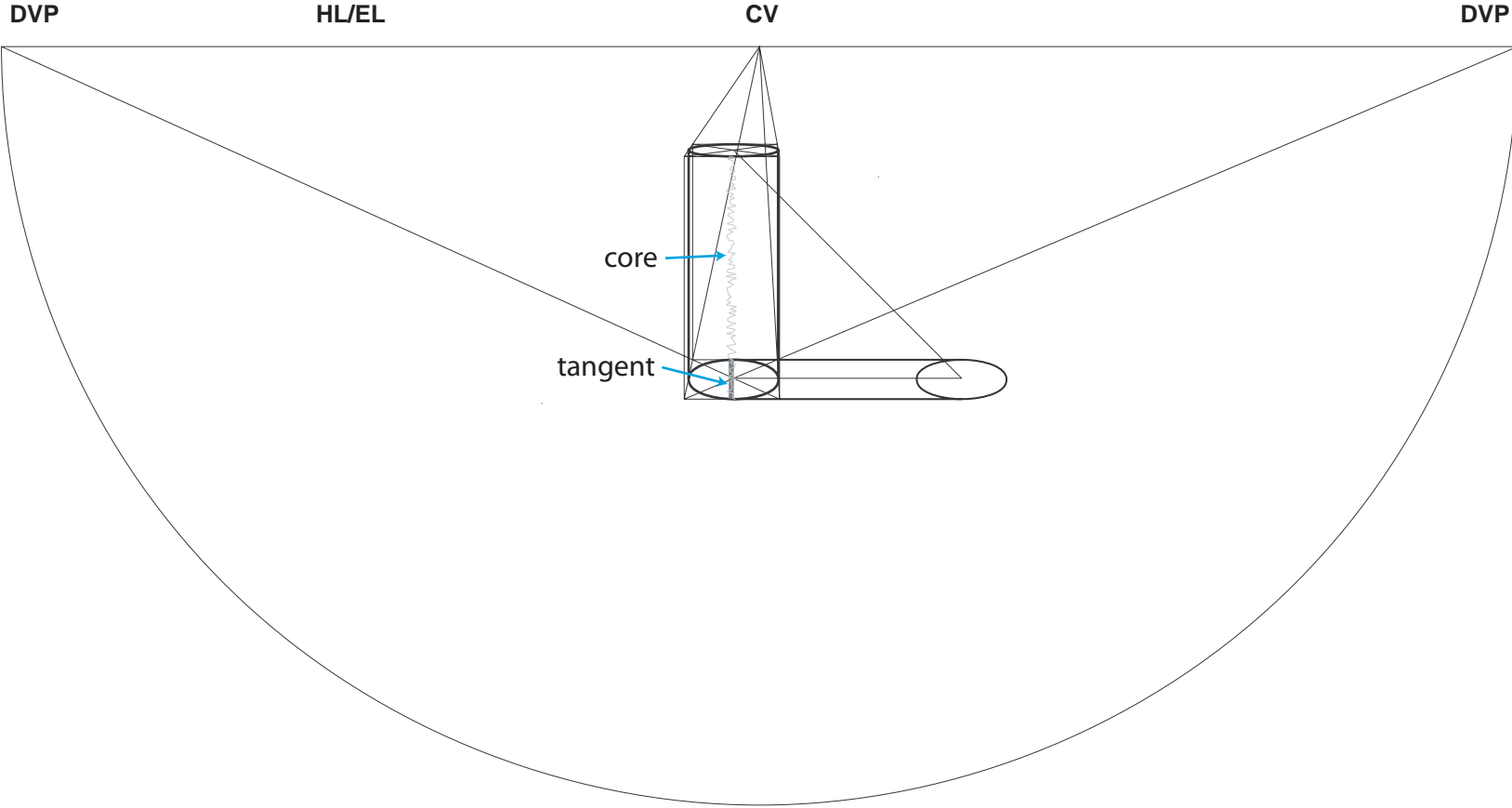

NOTES:

**step 6**  
Find the  
tangent and  
core